

AGRICULTURAL MACHINERY
sitrex®

**ASSEMBLY, USE
AND MAINTENANCE**

MX/12

CONTENTS

CONTENTS	1
1. Warrantee	2
2. Technical characteristics	3
3. General instructions for the operation and maintenance	4
4. Assembly instructions	5
4.1 Warning signs	5
4.2 Danger signs	6
4.3 Technical notes	6
5. Assembly steps	9
6. Connection to the tractor and transport	38
7. General instructions for field use	41
8. General maintenance instructions	45
8.1 Repair work	45
8.2 Laying up for extended periods	45
8.3 Maintenance direction	46
9. Central wheels kit: instructions for installation	47
10. Central wheels kit: adjustment for use	52

1. Warrantee

On delivery, check that the machine has not been damaged during transport and that all the attachments are present. Claims must be made in writing to the agent within 8 days of receipt.

The manufacturer warrants new machinery at the time of delivery to the original purchaser to be free from defects in material and workmanship if properly set up and operated in accordance with this Operator's Manual.

The manufacturer undertakes to repair or replace free of charge any defective part which should be returned by the purchaser (freight prepaid) and found to be defective by inspection authorized by the manufacturer during the warranty period.

This warranty will be valid for 12 (twelve) months from the delivery of goods to the original purchaser.

In case the customer is not in a position to return the defective part to the manufacturer, the manufacturer cannot be held responsible for any cost due for repair or replacement of any part of the machine, he will only supply the part(s) required for the repair and/or replacement.

The warranty is null and void when it is evident that the machine has been improperly used or repaired or however repaired without authorization.

The manufacturer undertakes no responsibility for any obligation or agreement reached by any employers, agents or dealers, which are not in compliance with the above warranty. The manufacturer cannot be held responsible for the consequent damages. This warranty substitutes any other warranty, express or implied, and any other manufacturer's obligation.

2. Technical characteristics

Type of machine		MX 12
Number of fingerwheels	n°	12
Number of tines for wheels	n°	40
Working width	m (feet)	7.1 (23' 3)
Operating speed	km/h (Mph)	22.5 (14)
Minimum power required	kW (HP)	22.4 (30)
Weight	kg (Lbs)	1425 (3140)
Tyre size		205 - 65/15
Transport width	m (feet)	2.5 (8' 3")

3. General instructions for the operation and maintenance

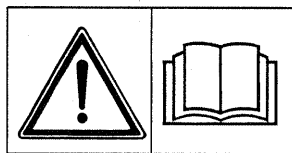

Before starting off for work, be sure that the machine is correctly assembled and in good operating condition.

The front transport arms must always be attached during transport.

While the front transport arms are attached, do not operate for any reason whatsoever the hydraulic cylinders for opening the machine or lifting the rake wheels.

When the machine is in movement, make sure that the brake on the front wheels does not block wheel movement. The wheels must always pivot freely.

When in operation, do not turn around at full speed.

On particularly uneven ground, do not operate with the machine in the fully-opened position (close machine at least 3' compared to the fully-opened position). In addition, operate at a reduced speed.

If it is noticed that the machine is not operating properly (rake wheels putting too much pressure on the ground, front wheels braked, etc.) the problem must be corrected immediately to avoid causing damage to the machine.

If machine maintenance work, repairs or adjustments must be done in the field, they should be done at a spot where the ground is firm and level. Turn off the tractor and apply the parking brake. Use the proper tools and wear suitable protection (safety goggles, work gloves, etc.).

If any maintenance work, repairs or adjustments are done which require that some parts be removed and/or that screws, nuts, pins, etc. be loosened or removed, always make sure that everything is reassembled or retightened as it had been prior to making repairs or adjustments.

Follow the schedule provided for maintenance.

By following these suggestions it will be possible to keep the machine operating safely and efficiently, to the benefit of the user.

IMPORTANT

DURING EXTENDED PERIODS OF INACTIVITY IT IS NECESSARY TO CLOSE COMPLETELY THE CYLINDERS. THIS MUST BE DONE IN SUCH A WAY AS TO PROTECT THE RODS FROM WEATHER EFFECTS.

THE RODS PARTS REMAINING OUTSIDE THE CYLINDER PIPE (WHATEVER REASONS MAY BE) MUST BE CAREFULLY PROTECTED WITH A GREASE LAYER.

4. Assembly instructions

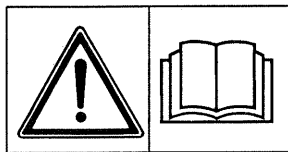

Assembly must be done carefully and accurately, for the safety of the person(s) doing the assembling and to ensure proper machine operation.

Assembly should be done on a flat, solid surface, using the proper tools and wearing suitable clothing, making sure that all people not involved in the assembly be kept at a safe distance. Assemblers must provide suitable lifting mechanisms and supports for stabilizing the partially assembled units, so as to prevent them from falling and causing damage or injury. The steps for assembly are illustrated in following. Depending on the experience of the assemblers and the tools available, it is not necessary that the instructions be followed in the exact order given here, but the safety precautions described above must always be followed carefully and scrupulously.

IMPORTANT

These signs and symbols give information to the operator on how to make the best use of the machine so as to prolong life, avoid damage, optimise work and, above all, to avoid injury to the operator and anyone within range of the machine.

4.1 Warning signs

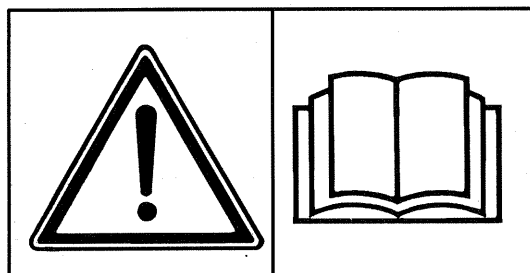

A) Before beginning operations, read the instruction manual carefully.

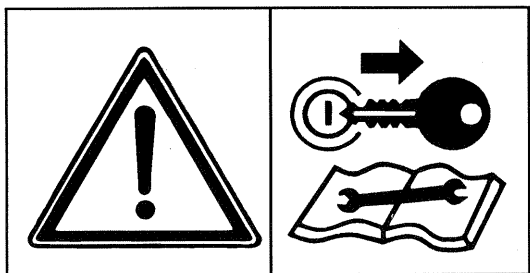

B) Before doing any maintenance or repair work, stop the machine at a suitable spot. Turn off the tractor motor, apply the brake, remove the key from the ignition and consult this manual.

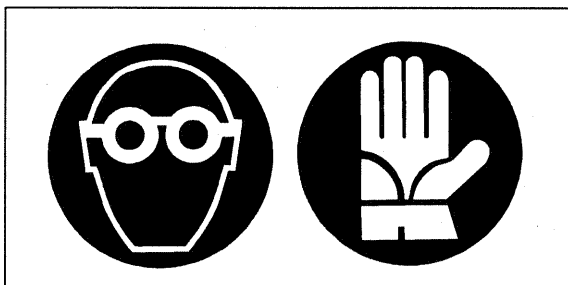

C) This is a warning to use proper accident protection when carrying out maintenance and repairs

4.2 Danger signs

DANGER



Indicates an impending dangerous situation which, if not avoided, will cause death or severe personal injury.

ATTENTION



Indicates a potentially dangerous situation which, if not avoided, could cause death or severe personal injury, including dangers which are present when protection is removed.

CAUTION



indicates a potentially dangerous situation which, if not avoided, can provoke less severe or minor injuries.

4.3 Technical notes

We will provide a few examples to make it easier to choose which of the various accessories to use for each step of assembly. An approximate equivalent of the metric measurements is given in inches.

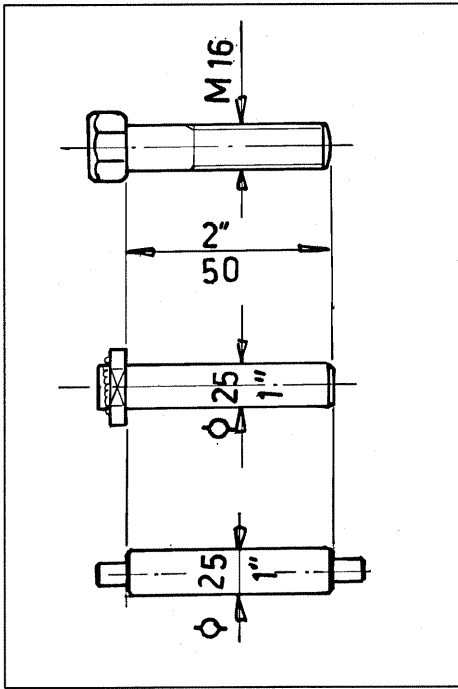

1) PINS AND SCREWS

Example: a pin with a 25 mm (1") diameter and a screw with an M 16 (5/8") diameter, both 50 mm (2") long, will be listed as:

D 25 x 50 (D 1" x 2") and M 16 x 50 (D 5/8" x 2").

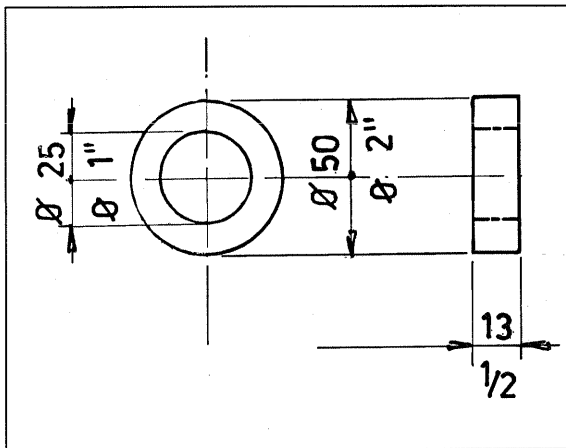

2) SHIMS, SPACERS, BUSHINGS AND WASHERS

Example: a shim, spacer, bushing or washer with an inside diameter of 25 mm (1"), outside diameter of 50 mm (2") and thickness or length of 13 mm (1/2") will be listed as:

D 25 - 50 x 13 (D 1" - 2" x 1/2").

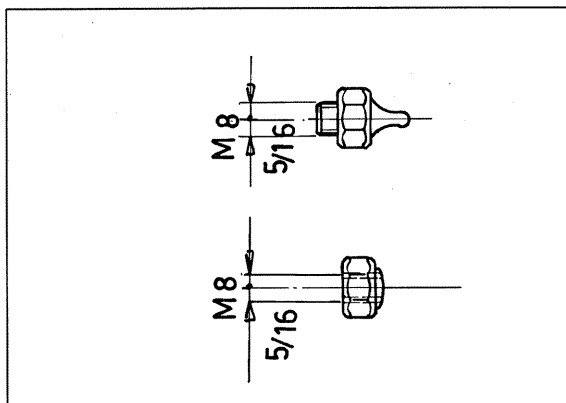

3) NUTS, GREASE NIPPLES

Example: a nut or grease nipple having a thread of M 8 (5/16") will be listed as:

M 8 (5/16")

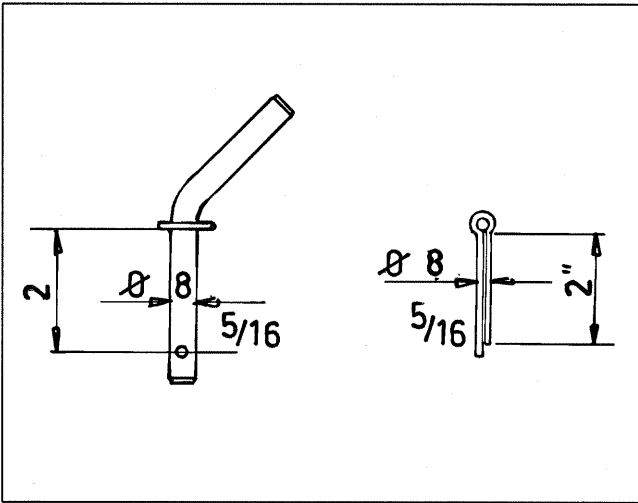

4) PINS AND SPLIT PINS

Example: a pin or split pin having a diameter of 8 mm (5/16") and a length of 50 mm (2") will be listed as:
 D 8 x 50 (D 5/16" x 2")

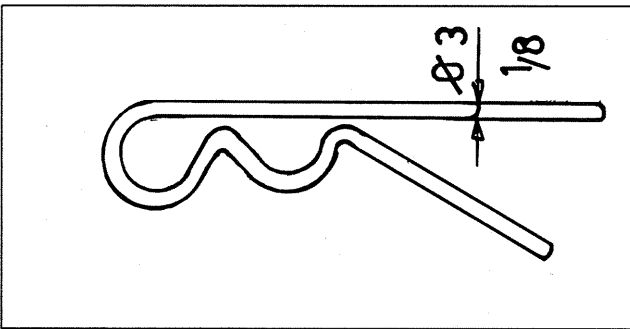

5) CLIPS

Example: a clip with a diameter of 3 mm (1/8") will be listed as:
 D 3 mm (1/8")

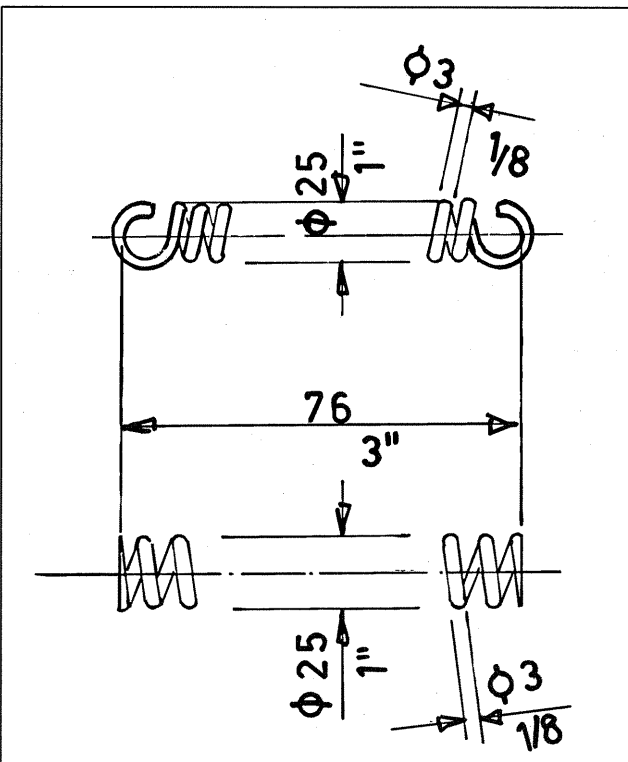

6) SPRINGS

Example: a spring with a wire diameter of 3 mm (1/8"), outside diameter of 25 mm (1") and length of 76 mm (3") will be listed as:
 D 3 - 50 x 76 (D 1/8" - 2" x 3")

5. Assembly steps

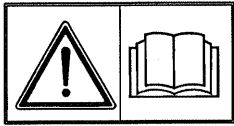

In the steps for assembly we will use the terms "RH part" and "LH part". The distinction is conventionally made looking at the machine from the rear. For the purpose of simplification, we will illustrate machine assembly for one side only; since the machine is symmetrical, each operation must be done on both sides.

1. ATTENTION

Fit bushings 4 on proper seats of uprights 2 & 3. Attach the wheel supports 2 & 3 (LH - RH) to the

cross member assembly 1 using pins 5, washers 6 & 7 and screws 8. To identify parts 2 & 3 (LH - RH) see the next step.

NOTE: measurement labels (see next figure) must be read from the rear side of the machine.

In this step, you will use:

Item 4:
4 - bushings D 50 - 60 x 50
(D 2" - 2" 3/8 x 2")

Item 5:
2 - pins D 50 x 190
(D 2" x 7" 1/2)

Item 6:
2 - washers D 23 - 75 x 12
(D 29/32" - 3" x 1/2)

Item 7:
2 - Grower washers
D 23-35x4
(29/32" - 13/8" x 5/32")

Item 8:
2 - screws M 22 x 50
(7/8" x 2")

Item 9:
2 - grease nipples M 8
(5/16")

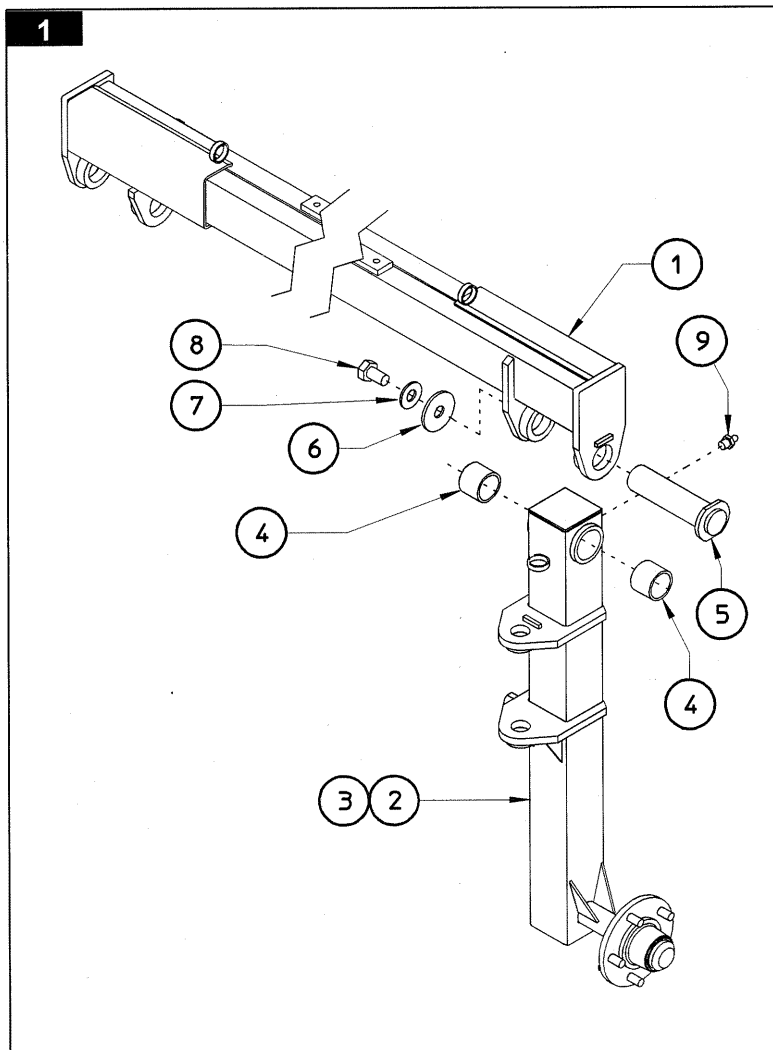

2.

For correct assembly, the RH support 3 and the LH support 2 must lean in slightly towards the center of the machine. After assembly, they must have the measurements given (minimum width). At this point, before moving on to next step, keep in mind that the assembly is unstable and therefore it is recommended that extreme caution be used.

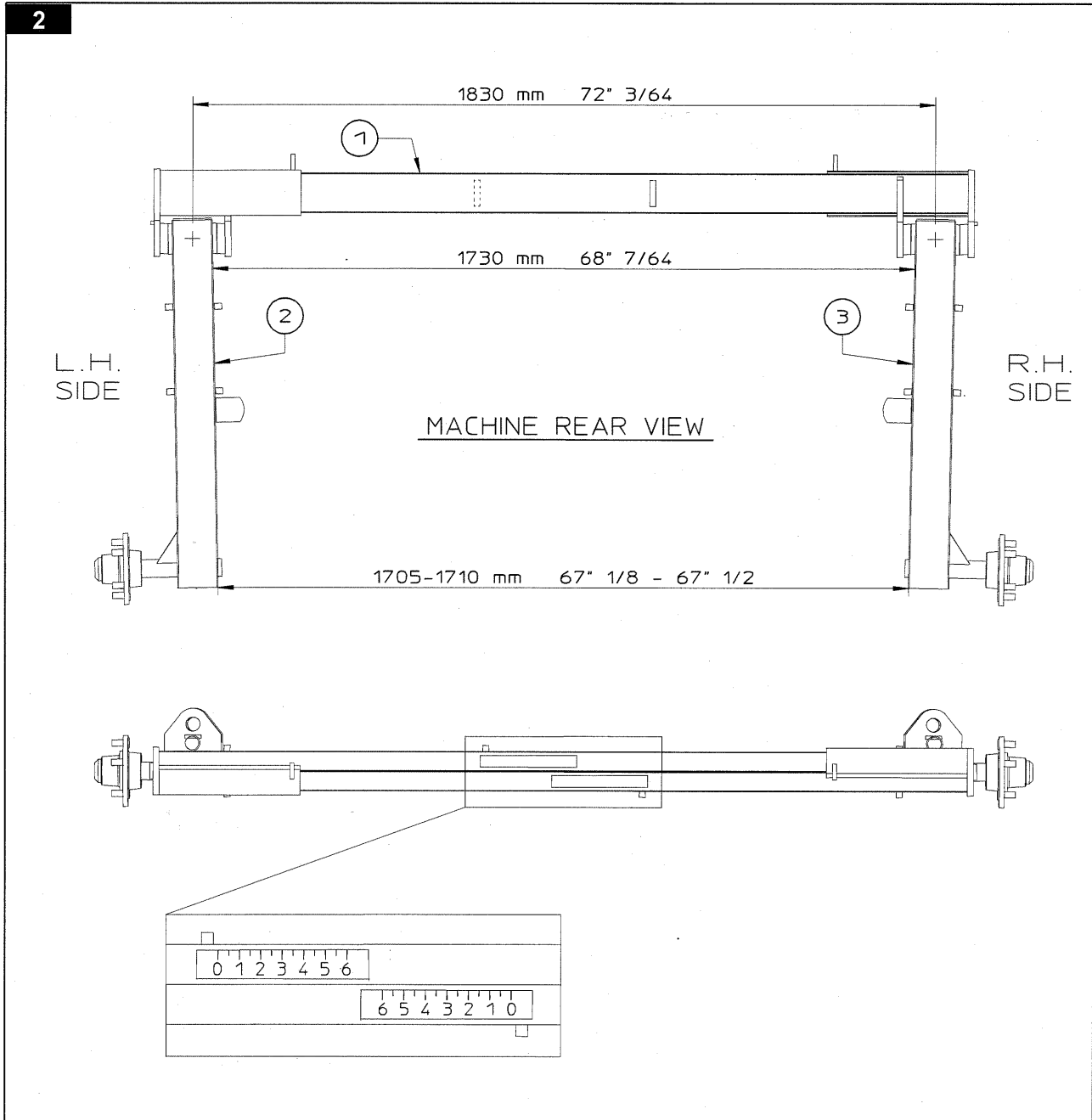

NOTE: For the windrow width's adjustment see page 43.

3. ATTENTION

Attach plates 1 to cross member A. This is done in the following manner:

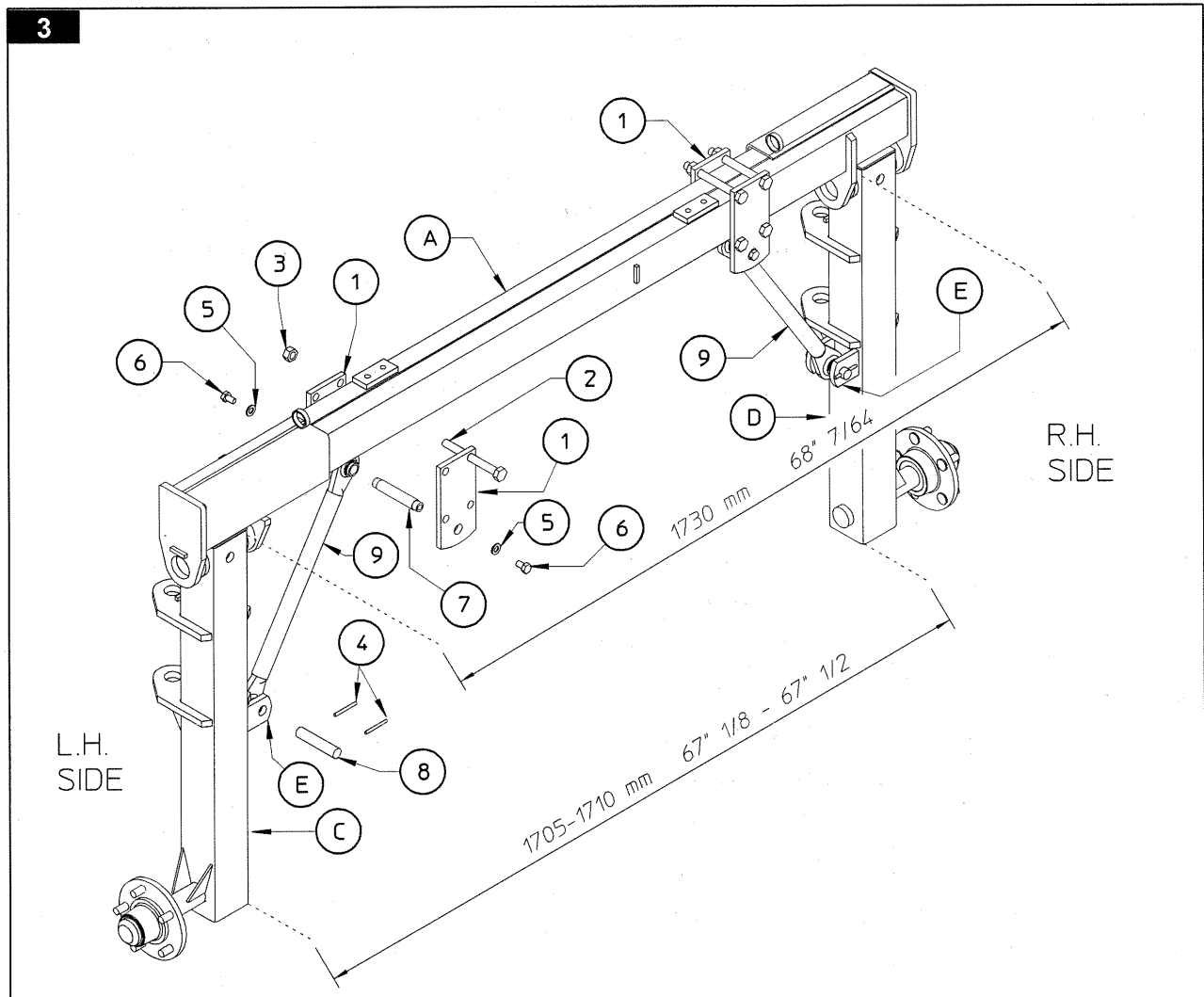

a) Insert screws 2 in the two upper holes of plates 1. Fasten screws 2 with nuts 3 without fully tightening them, so that plates 1 are straddling cross member A.

b) Insert pin 7 in one of the joints of tie rod 9.

c) Insert pin 7, supporting tie rod 9, between plates 1.

d) Now insert screws 2 in the lower holes of plates 1. Fasten with nuts 3, without fully tightening.

e) At this point, insert the other joints of tie rod 9 between the welded plates E (LH support C and RH support D) and fasten with the pins 8 and spring pin 4.

f) Check that the plates and tie rods are in the correct position, and then fasten pins 7 to plates 1 using washers 5 and screws 6.

g) Securely fasten plates 1 by fully tightening nuts 3. For this step you will use:

In this step, you will use:

Item 2:
8 - screws M 16 x 165 (5/8" x 6" 1/2)

Item 3:
8 - nuts M 16 (5/8")

Item 4:
4 - spring pin D 5 x 36
(D 1" 13/64 x 1" 27/64)

Item 5:
4 - washers D 12-36 x 2.5 (D 1/2" - 1" 27/64 x 3/32")

Item 6:
4 - screws M 12 x 20 (1" 5/32" x 13/16")

Item 7:
2 - pins D 22 x 120 (D 7/8" x 4" 23/32)

Item 8:
2 - pins D 22 x 108 (D 7/8" x 4" 1/4)

4. DANGER



Mount wheels 4 to hubs 1 (supports 2 & 3) using special nuts 5.

In this step, you will use:

Item 5:
10 - nuts M 16
(5/8"), fine pitch and spherical cap.

NOTE: the spherical side "A" of the nut 5 must be always turned towards the wheel rim flange.

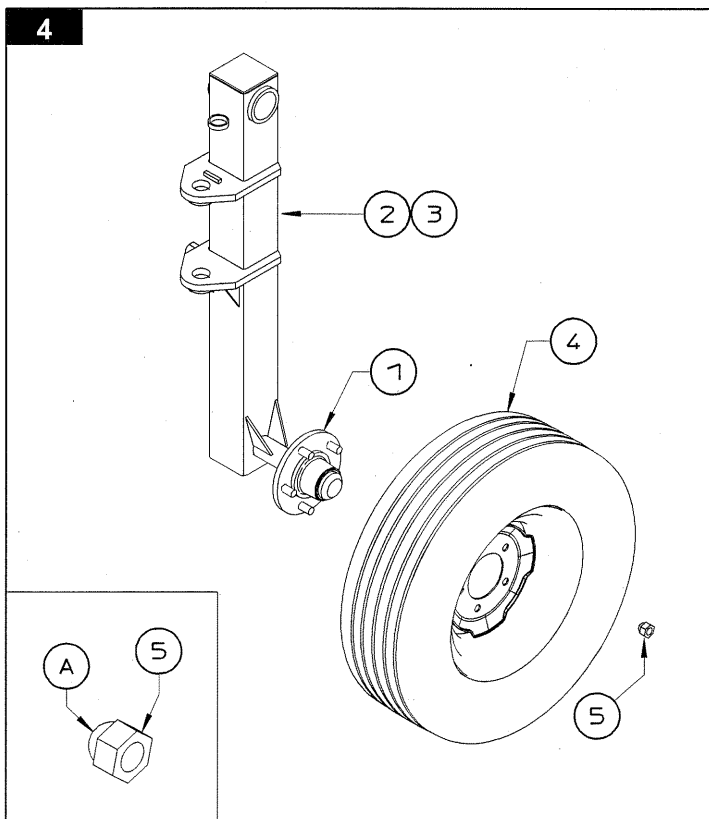

5. DANGER 

Assembly 1 must be fully firmly stabilized. Wheels must be chocked with chocks 2 and a support

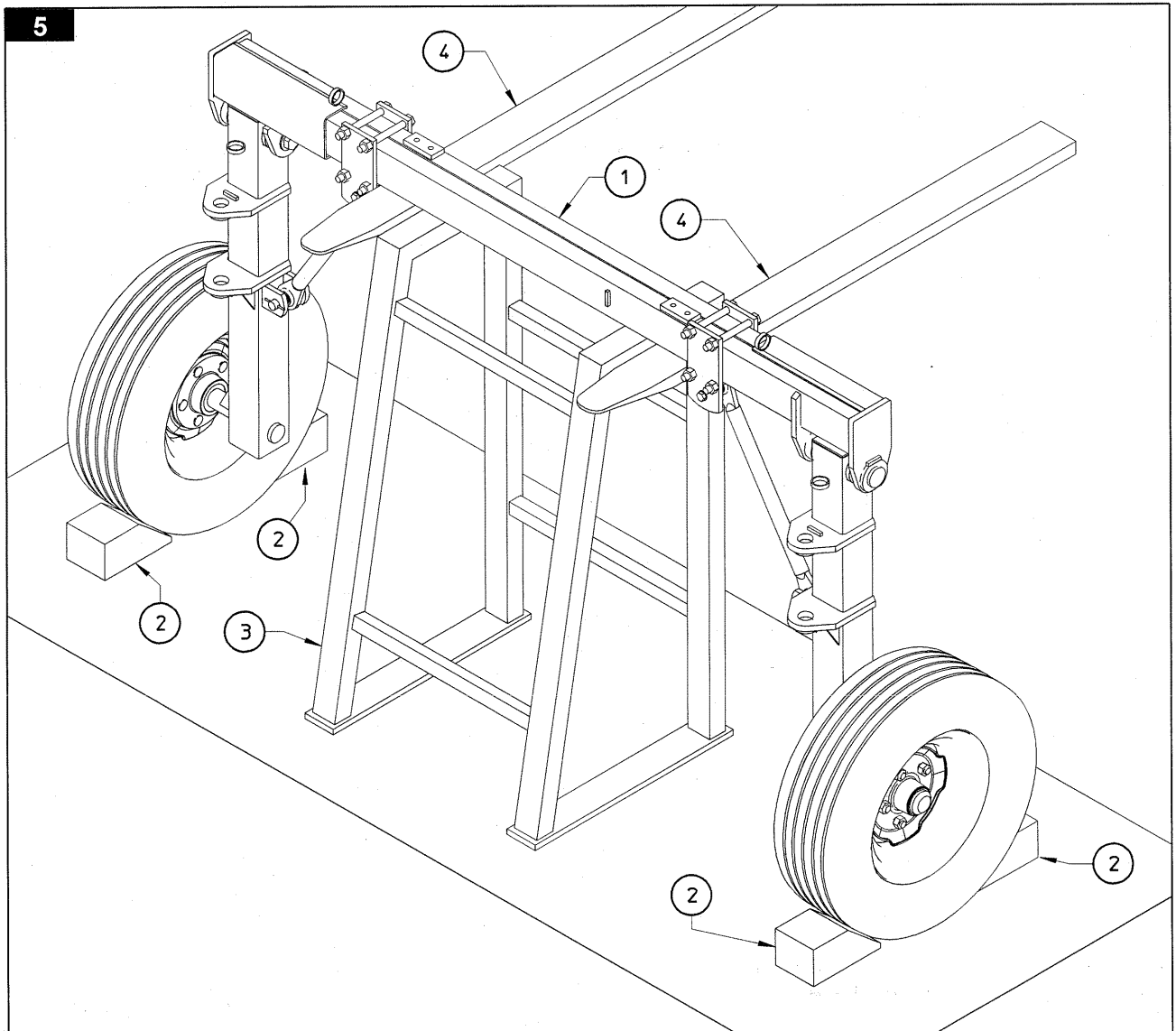

3 must be placed under the cross member. The forks 4 of a forklift may also be used to support the assembly.

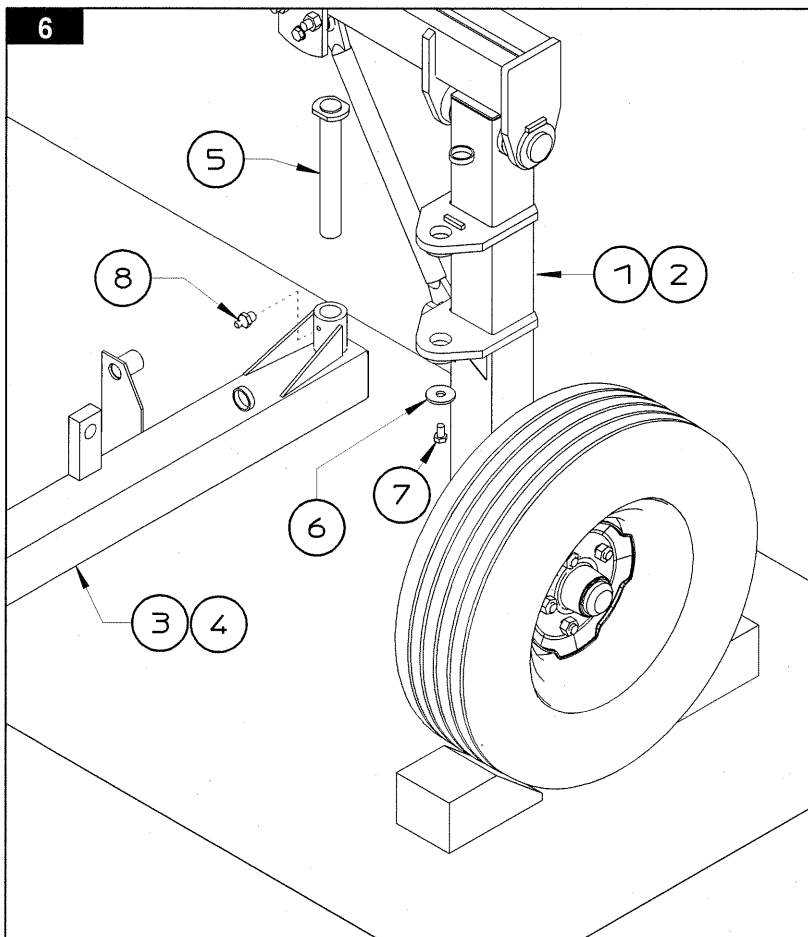

6. DANGER



Attach the rake wheel sections 3 & 4 (LH - RH) to supports 1 & 2 (LH - RH) using pin 5, washer 6 and screw 7. Attach grease nipple 8 in the proper hole.

In this step, you will use:

Item 5:
2 - pins D 35 x 242
(D 1" 3/8" x 9" 1/2)

Item 6:
2 - washers D 12-40 x 4
(D 1/12" - 1" 9/16 x 5/32")

Item 7:
2 - screws M 12 x 20
(15/32" x 13/16")

Item 8:
2 - grease nipples M 8
(5/16")

7. ATTENTION



Attach sections 3 & 4 (LH -RH) to the initial sections 1 & 2 (LH - RH) using screws 5 and nuts 6. Fit in every wheels pipe bushings the grease nipple 7.

In this step, you will use:

Item 5:
8 - screws M 16 x 45
(5/8" x 1" 3/4)

Item 6:
8 - nuts M 16
(5/8")

Item 7:
12 - grease nipples M
6x45°
(1/4")

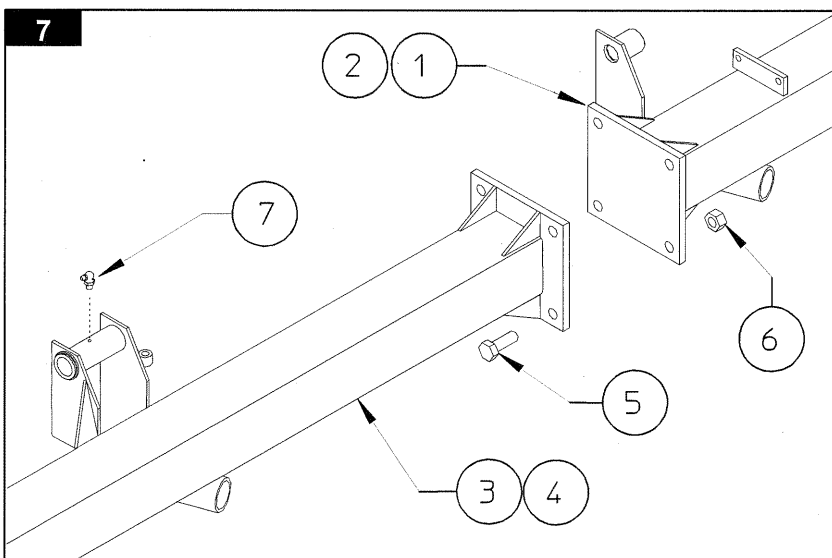

8. ATTENTION

Attach end sections 3 & 4 (LH - RH) to sections 1 & 2 (LH - RH) using screws 5 and nuts 6. Insert bushings 7 in the correct openings in end sections 3 & 4 (LH - RH) and fasten in place with spring pins 8.

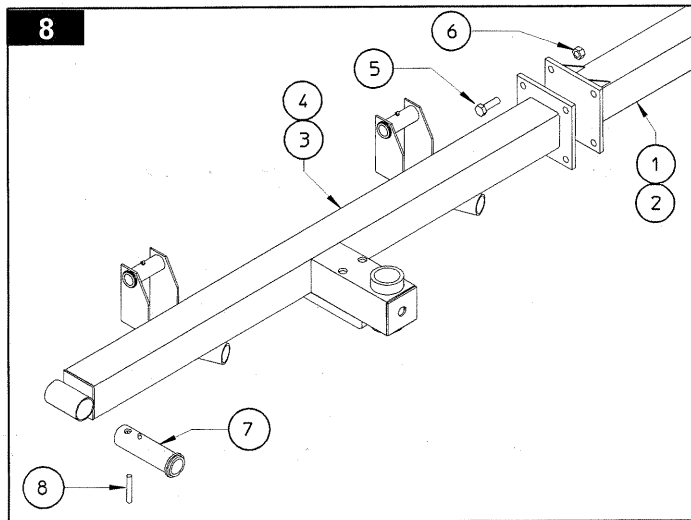

In this step, you will use:

Item 5:
8 - screws M 16 x 45
(5/8" x 1" 3/4)

Item 6:
8 - nuts M 16
(5/8")

Item 8:
2 - spring pins D 8 x 70
(D 5/16" x 2" 3/4)

9.

When reaching this point, work with great caution, as the machine is not stable.

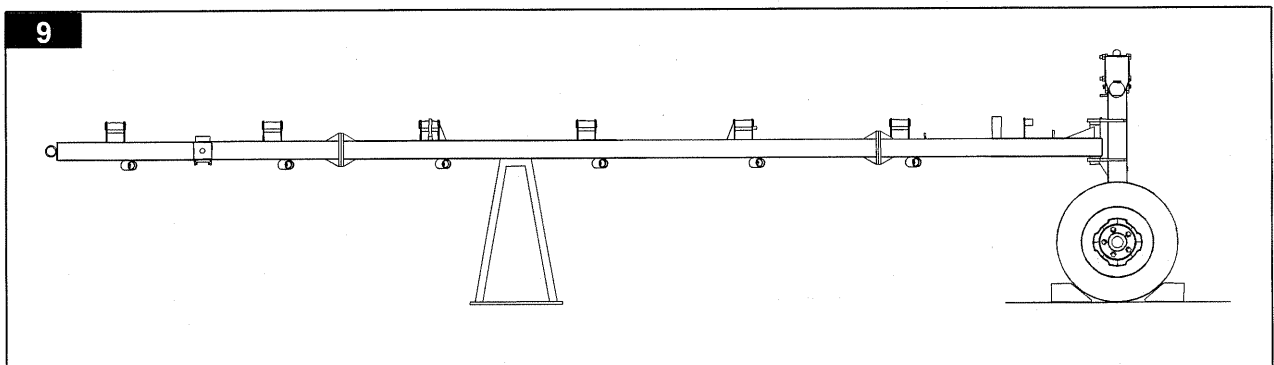

10. CAUTION



Attach hub 1 to wheel 2 using screws 3 and nuts 4. Be sure to follow the indications in the illustration during mounting.

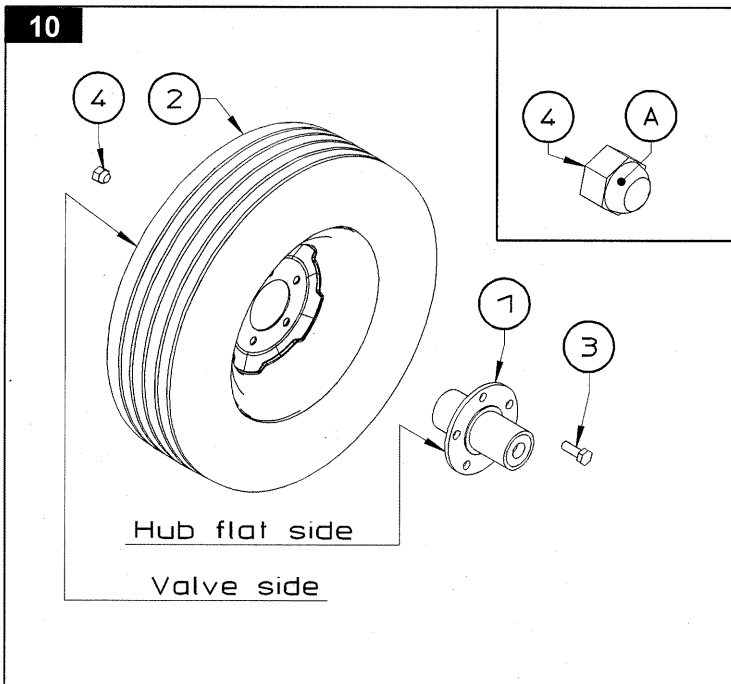

In this step, you will use:

Item 3:
10 - screws M 16 x 1.5 x 40
(5/8" x 1" 19/32" fine pitch)

Item 4:
10 - nuts M 16 x 1.5
(5/8" fine pitch).

NOTE: the spherical side "A" off the nut 7 must be always turned towards the wheel rim flange.

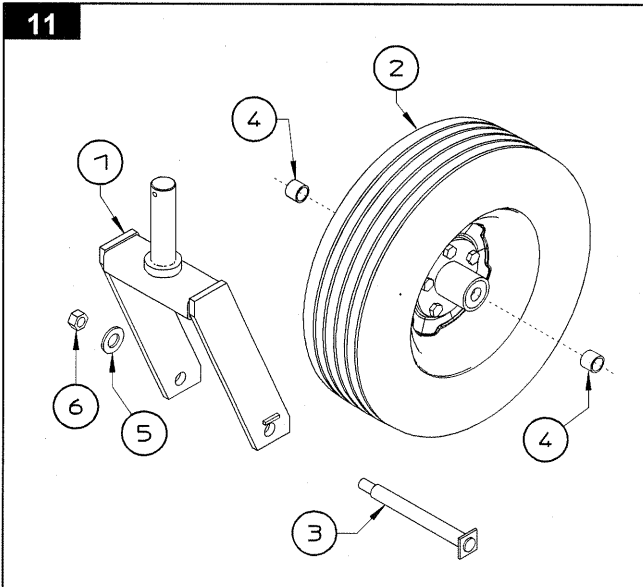

11. CAUTION



Mount wheel-hub assembly 2 on bracket 1 using pin 3, spacers 4, washer 5 and nut 6.

in this step, you will use:

Item 3:
2 - pins D 30 x 270
(D 1" 13/16 x 10" 5/8)

Item 4:
4 - spacers D 30-38 x 30
(D 1" 3/16 - 1" 1/2" x 1" 3/16)

Item 5:
2 - washers D 23-50 x 4
(D 7/8" - 2" x 5/32")

Item 6:
2 - nuts M 22 (7/8").

12. ATTENTION

Insert bushings 5 in the holes in sections 1 & 2 (LH - RH) shown in the illustration. Place the antifriction washer 4 on the pin of wheel assembly 3, and insert the wheel assembly pin in the correct holes in sections 1 & 2 (LH - RH) and secure it with the flanged bushing 6 and the spring pin 7. Attach grease nipples 8 to the correct holes of sections 1 & 2 (LH - RH).

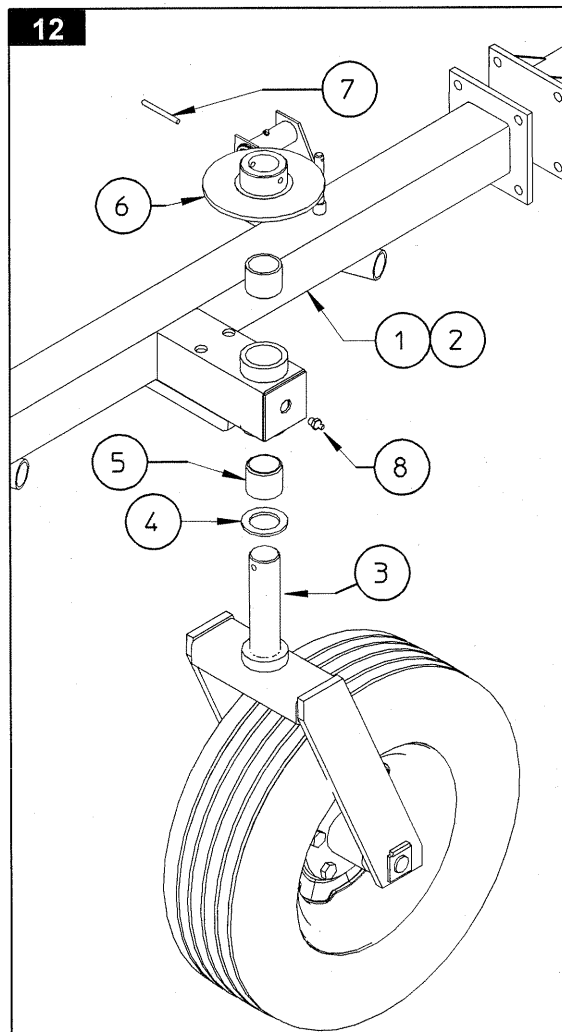

In this step, you will use:

Item 4:

2 - washers D 50-76 x 5
(D 2"-3" x 3/16")

Item 5:

4 - bushings D 50-60 x 50
(D 2"-2" 3/8 x 2")

Item 7:

2 - spring pins D 10 x 80
(D 13/32" x 3" 5/32)

Item 8:

2 - grease nipples M 8
(5/16")

13. CAUTION



Place plate 2 with screw under flange 1 as shown in the illustration. Place upper plate 4 over screw 3, followed by spring 5 and washer 6, and tighten with nut 7.

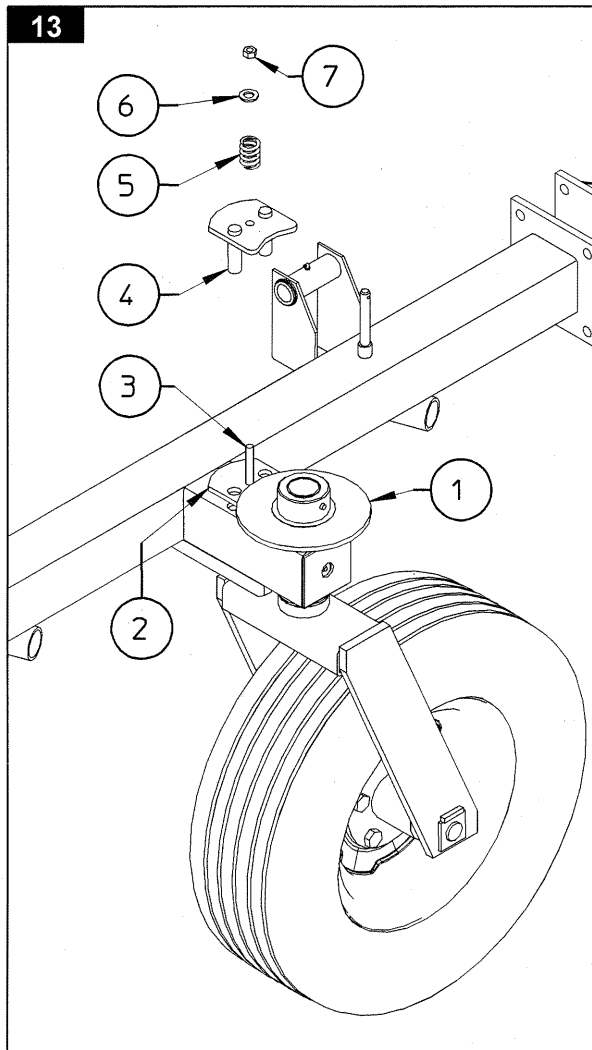

NOTE: nut 7 should be tightened so as to allow the bracket to pivot freely.

In this step, you will use:

Item 5:
2 - springs D 5-30 x 45
(D 13/64" - 1" 3/16" x 1" 25/32")

Item 6:
2 - washers D 12-36 x 2.5
(D 15/32" - 1" 27/64" x 3/32")

Item 7:
2 - nuts M 12
(15/32")

14.

The machine is now resting on four wheels and is thus more stable; however, caution should still be used for the remaining assembly steps. To make assembly easier, it is recommended that the machine sections opened out.

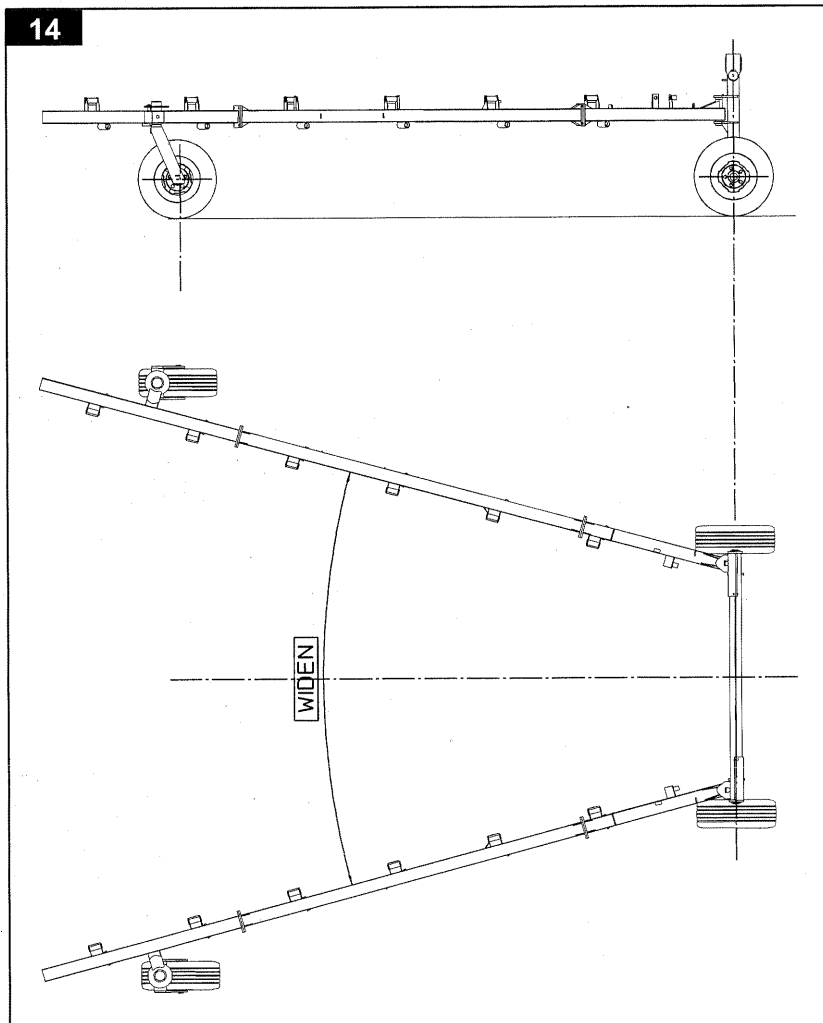

15. DANGER



This operation is to be carried out with the aid of supports and a jack or hoist of suitable capacity. Weight of Part 2: 110 kg, 245 lbs.

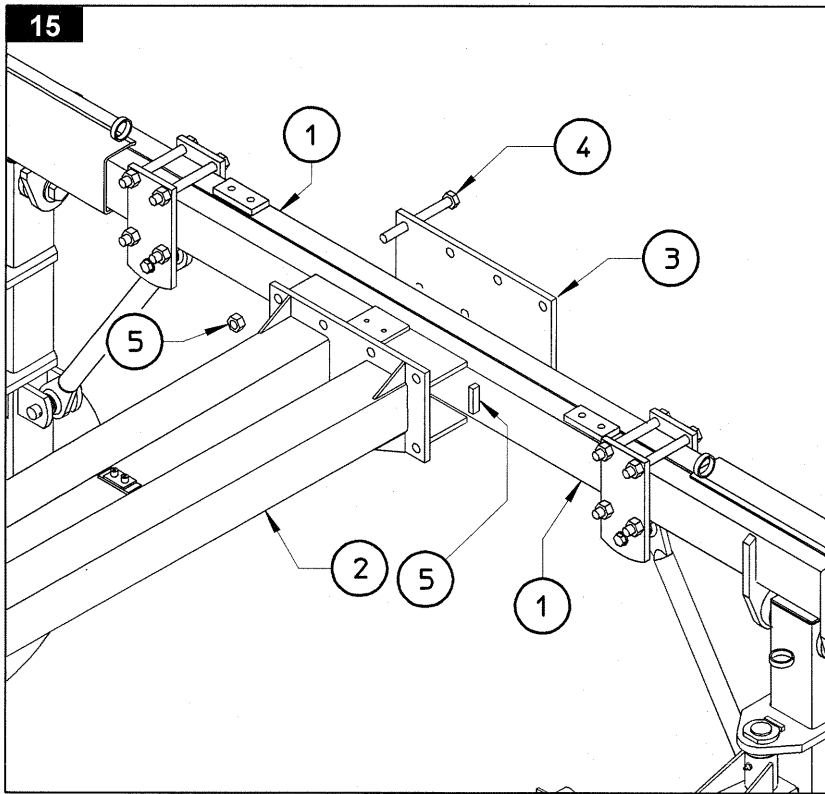

NOTE: Assemble the drawbar 2 in the middle of the cross members 1 only when the cross members 1 are pulled in together, so the drawbar 2 and counterplate 3 must be assembled between ledges 6 (see also figure 46).

Attach drawbar 2 to cross member assembly 1 using counterplate 3, screws 4 and nuts 5.

in this step, you will use:

Item 4:
8 - screws M 16 x 165
(5/8" x 5" 3/8)

Item 5:
8 - nuts M 16
(5/8")

16. DANGER

The rear drawbar section 1 must be stable, so it must be held either by a jack or hoist of suitable capacity or support 2 (weight 110 kg, 245 lbs.). Attach drawbar section 3 (weight 65 kg, 145 lbs.) to drawbar section 1 using screws 4 and nuts 5.

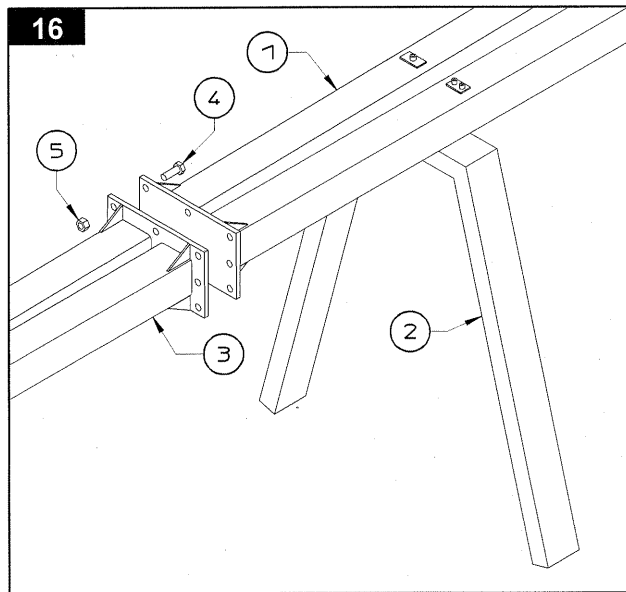

In this step, you will use:

Item 4:
8 - screws M 16 x 45
(5/8" x 1" 3/4)

Item 5:
8 - nuts M 16
(5/8")

17. DANGER

The center drawbar section 1 connected to the rear drawbar section must rest on support 2 or be supported by a jack or hoist of suitable capacity (weight of drawbar sections: 175 kg, 385 lbs.)

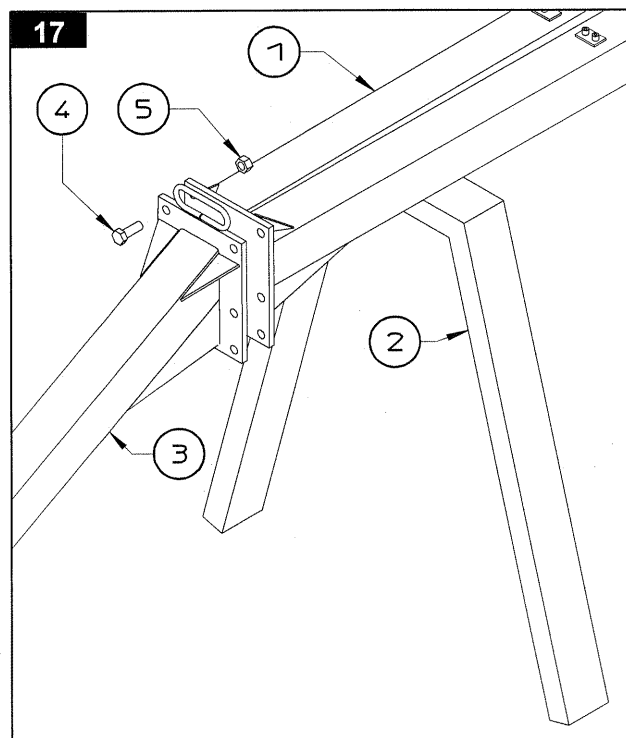

Attach the front drawbar section 3 to the center drawbar section using screws 4 and nuts 5.

In this step, you will use:

Item 4:
6 - screws M 16 x 45
(5/8" x 1" 3/4")

Item 5:
6 - nuts M 16
(5/8")

18. ATTENTION



Attach the parking stand 2 to the drawbar 1, fastening it with pin 3 and clip 4. The transport position of the parking stand is described on page 35. Insert bushings 5 in the correct holes in drawbar 1, fastening them with screw 7 and nut 6. Insert hitch 8 in the end of the drawbar and fasten with pins 9, washers 10 and nuts 11.

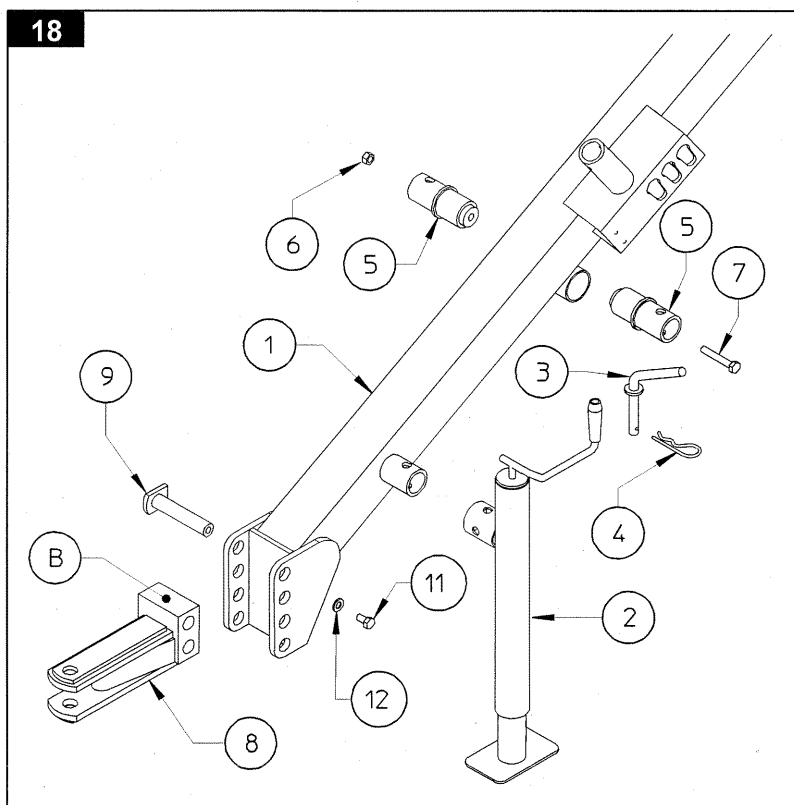

NOTE: Hitch 8 should be attached with flange B towards the top. To choose which hole should be used, see page 35.

In this step, you will use:

Item 3:
1 - pin D 15 x 85
(D 19/32" x 3" 11/32")

Item 4:
1 - clip D 3
(D 1/8")

Item 7:
1 - screw M 12 x 60
(15/32" x 2" 13/16)

Item 6:
1 - nut M 12
(15/32")

Item 9:
2 - pin D 25 x 124
(D 1" x 5")

Item 11:
2 - screw M 12 x 20
(15/32" x 13/16")

Item 12:
2 - washer D 12-36 x 2.5
(D 15/32" - 1" 13/32 x 3/32")

19. ATTENTION

Attach arms 3 & 4 (LH - RH) and counterplates 5 & 5a (LH - RH) to sections 1 & 2 (LH - RH), fastening them with screws 6 and nuts 7. See diagram for the correct positioning of the parts.

NOTE: When the machine is completely closed (cylinder 7), regulate the distances A & B with the ledges 6 to make the wheel section 1 & 2 (LH & RH) in parallel.

In this step, you will use:

Item 6:
16 - screws M 12 x 140
(D 15/32" x 5" 1/2)

Item 7:
16 - nuts M 12
(15/32")

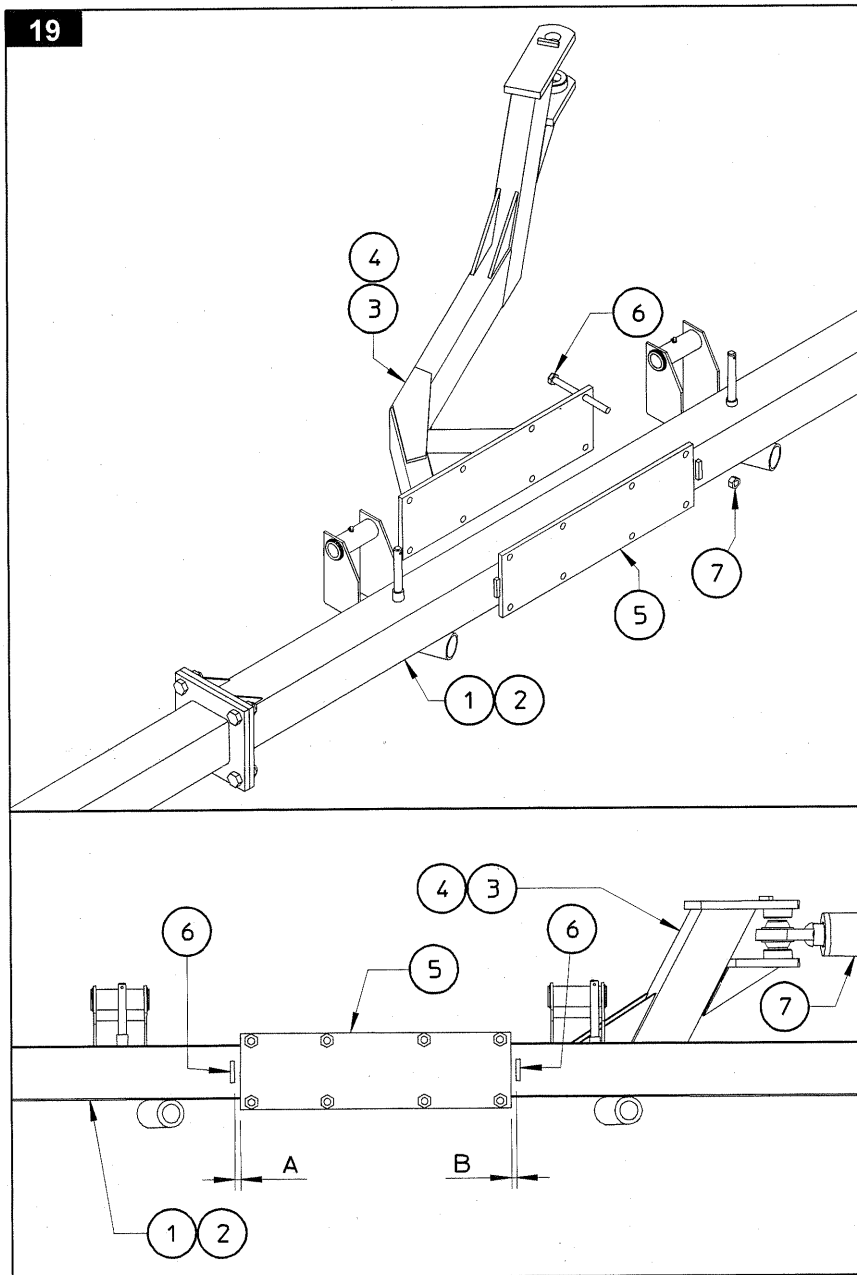

20.

You have now reached this stage of the assembly. The machine is now stable; however, caution is still recommended for the remaining assembly steps.

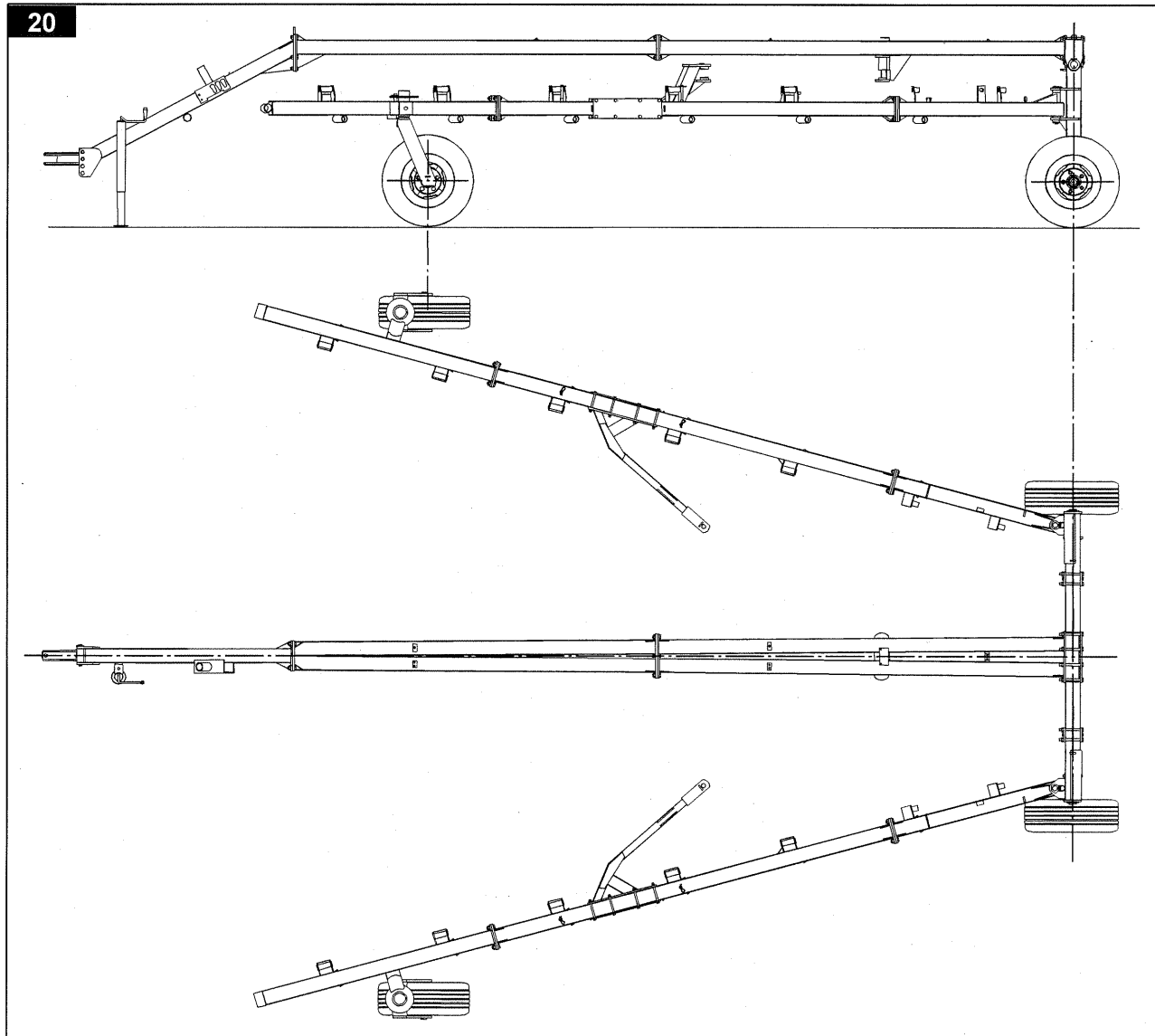

21. DANGER

Insert screw 3 in hand grip 2 and then screw it in the threaded hole in crank 1. Screw 3 should not be fully tightened, so that hand grip 2 can turn freely. Lock screw 3 in place with nut 4. Fit nut 5 onto the thread of crank 1.

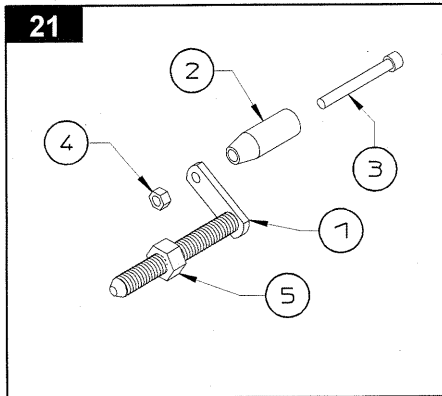

In this step, you will use:

Item 3:

2 - knurled-head screws M 12 x 100
(15/32" x 4")

Item 4:

2 - nuts M 12
(15/32")

Item 5:

2 - nuts M 22
(7/8").

22. CAUTION

Attach cylinder 1 to sections 2 & 3 (LH - RH) and fasten it with pin 6 and split-pins 5. Fit the

cylinder guides 9 to sections 2 & 3 (LH - RH) passing through point A and slot B. Fasten in place the cylinder guides 9 to sections 2 & 3 (LH - RH) with screws 7 and nuts 12.

Connect attachments 8 to the forks on the piston end of cylinders 1, fastening them with pins 4 and split pins 5. Insert crank 10 in the correct hole of bracket C. Then screw the plate 11 to crank 10. Screw the grease nipple 13 to bracket C.

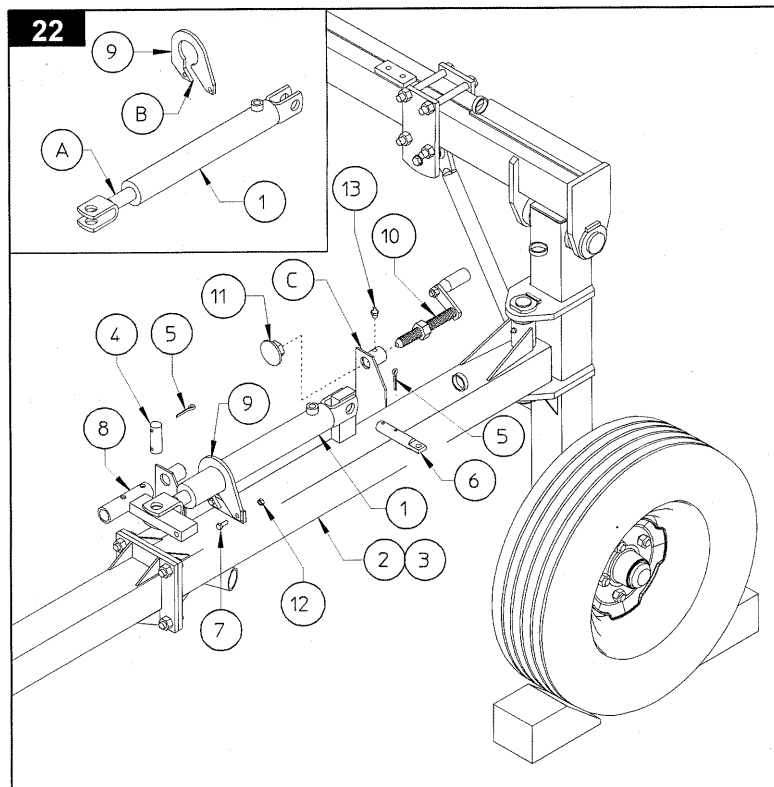

In this step, you will use:

Item 4:

2 - pins D 25 x 70
(D 1" x 2" 3/4")

Item 5:

4 - split pins D 6 x .35
(D 15/64" x 1" 3/8")

Item 6:

2 - pins D 25 x 132 (D 1" x 5" 3/16)

Item 12:

4 - nuts M 8 (D 5/16")

Item 7:

4 - screws M 8 x 25 (5/16" x 1").

Item 13:

2 - greasennipple M 6 (1/4)

23. CAUTION



Attach rake wheels lifting pipes 1-2 to sections 11 & 12 (LH - RH), beginning at point A. At the same time, the chain attachments 6 should be placed in the positions shown, as well as the connectors 4. Pipes 1 must also pass through the correct openings of attachments 5 (see figure 23.b). At this point connect attachments 5 to spots C on pipes 1, using screws 8 and nuts 9 (see figure 23.b). Connect pipes 1 & 2 using connectors 4, screws 8 and nuts 9. Fasten in the positions shown the chain attachments 6 using screw 7 (see figure 23.a).

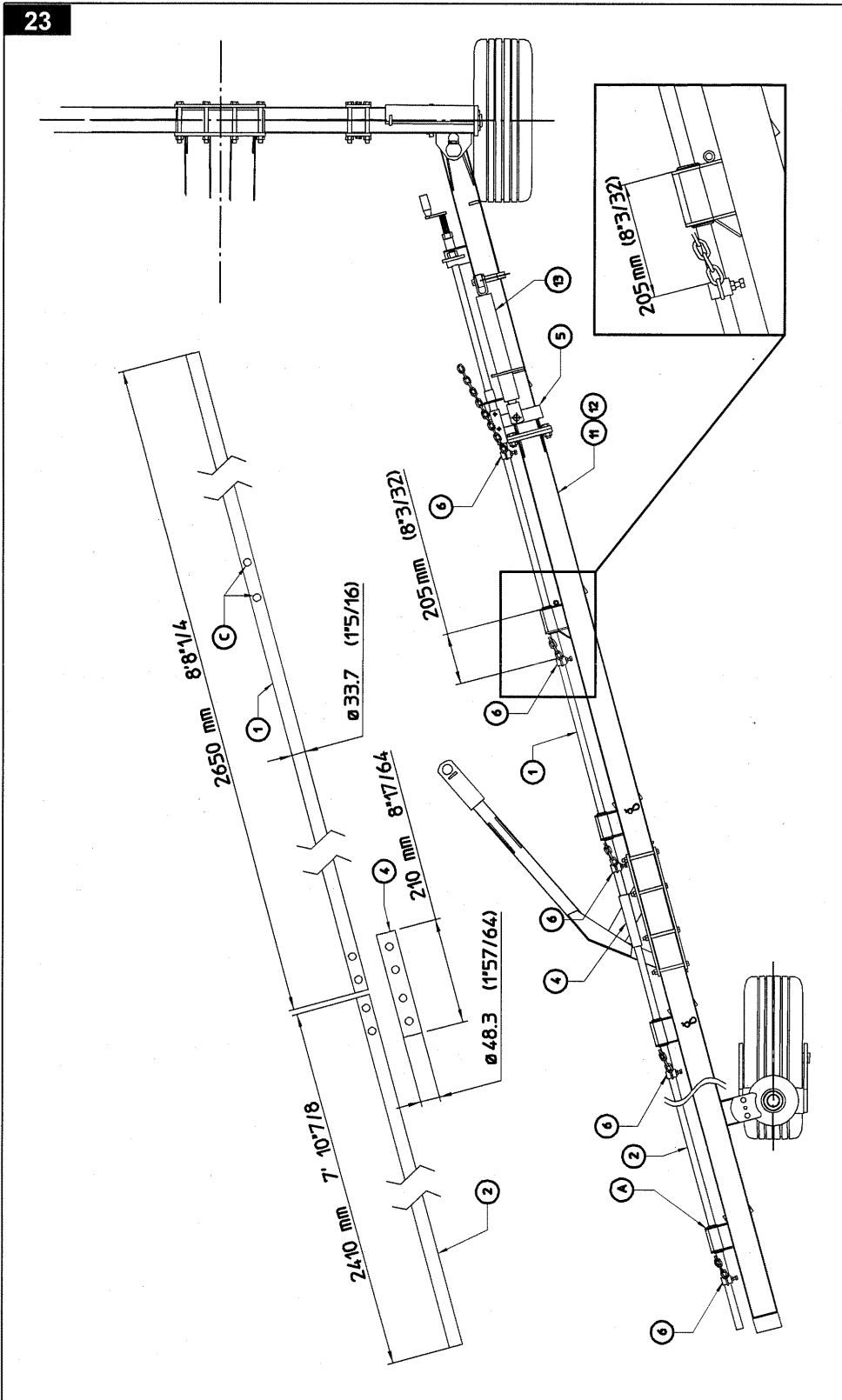

At the same time, the chain attachments 6 should be placed in the positions shown, as well as the connectors 4. Pipes 1 must also pass through the correct openings of attachments 5 (see figure 23.b). At this point connect attachments 5 to spots C on pipes 1, using screws 8 and nuts 9 (see figure 23.b). Connect pipes 1 & 2 using connectors 4, screws 8 and nuts 9. Fasten in the positions shown the chain attachments 6 using screw 7 (see figure 23.a).

In this step, you will use:

Item 7:
 12 - screws M 10 x 25
 (D 25/64" x 1")

Item 8:
 12 - screws M 8 x 60
 (5/16" x 2" 23/64)

Item 9:
 12 - nuts M 8
 (5/16")

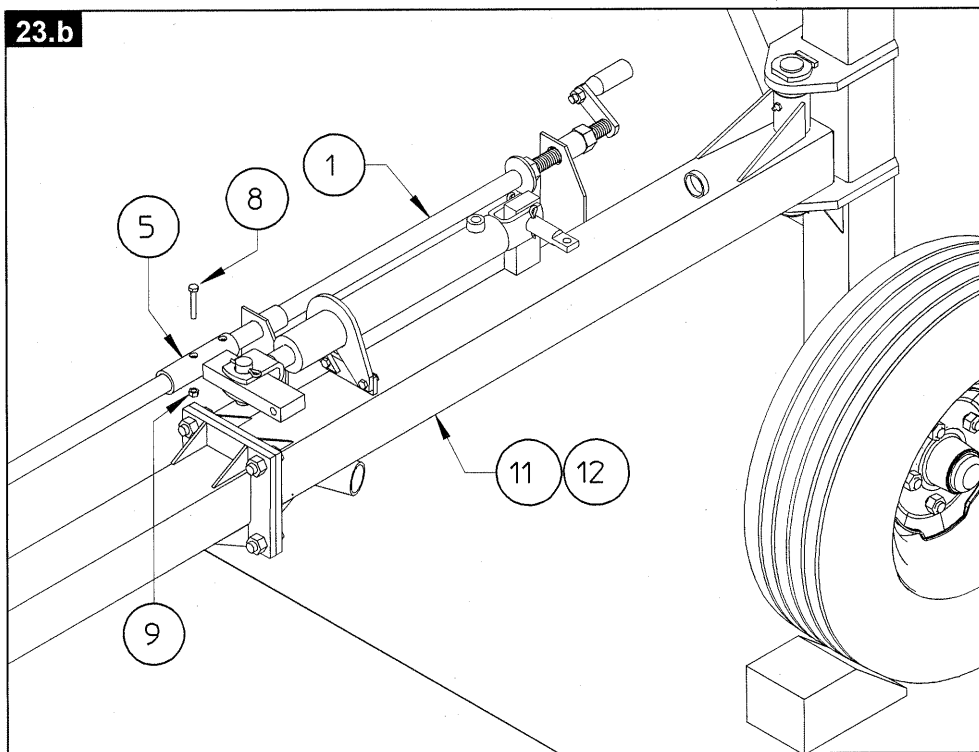
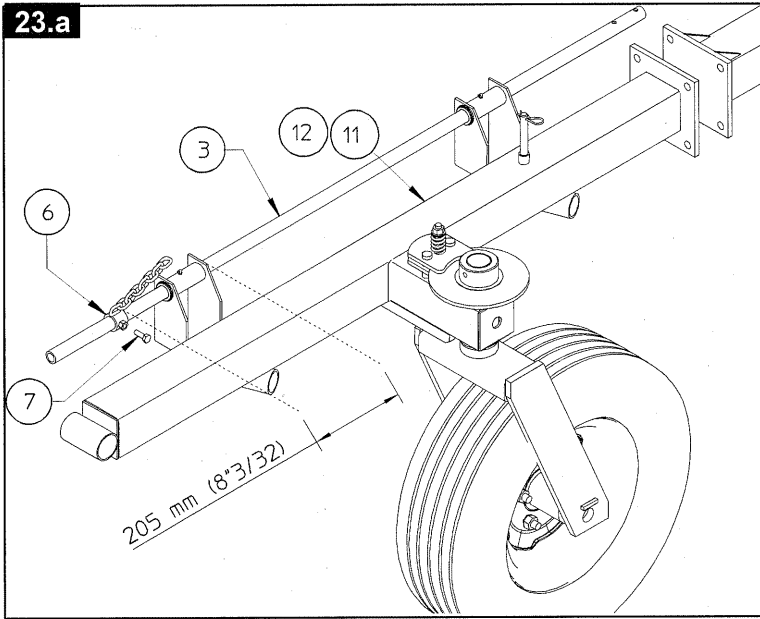

24.

First of all place stay bolts 1 inside springs 2. Attach spring 2 with stay bolt 1 to sections 3 & 4 (LH - RH) and attachments 5 as shown, fastening the spring-bolt assembly in place with nuts 6. Pasten stay bolts 1 with nuts 6 so that they extend 25 mm (1") from attachment 5, as shown.

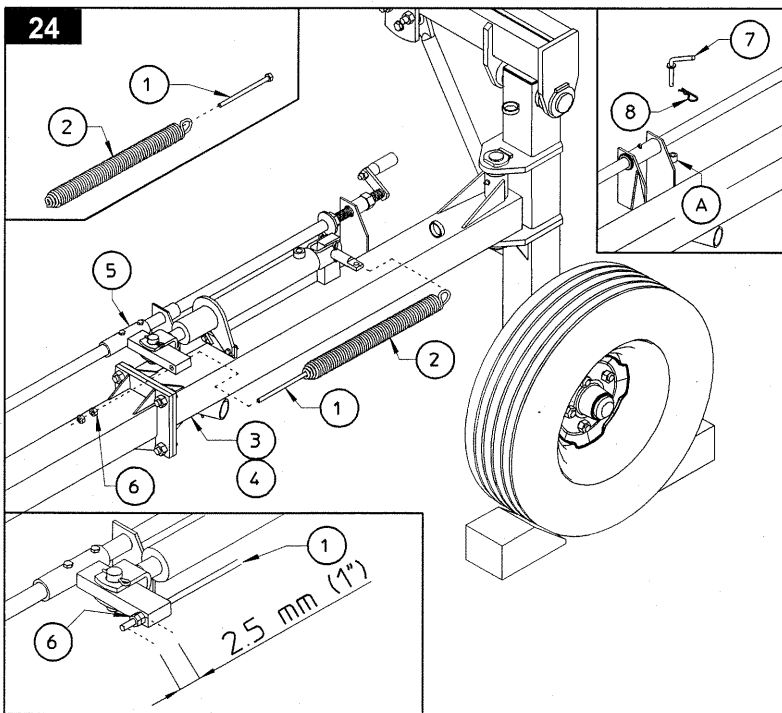

Insert pins 7 in the correct holes A, and fasten with clip 8.

In this step, you will use:

Item 6:

4 - nuts M10 (D 25/64")

Item 8:

2 - clips D 3 (1/8").

Item 9:

2 - pins D 10 x 48
(D 25/64" x 1" 7/8")

Item 7:

2 - pins D 10 x 63 (D 25/64" x 3" 30/64")

25. CAUTION



Attach bushings 1 and grease nipple 2 to rake wheel sections 12 & 13 (LH - RH) as shown. Attach rake wheel brackets 3 & 4 (LH - RH) to sections 12 & 13 (LH - RH) and fasten with washers 5 and spring pins 6. Mount rake wheels 7 & 8 (LH - RH) to rake wheel arms 3 & 4 (LH - RH) and fasten with screws 9, grower washers 10 and nuts 11.

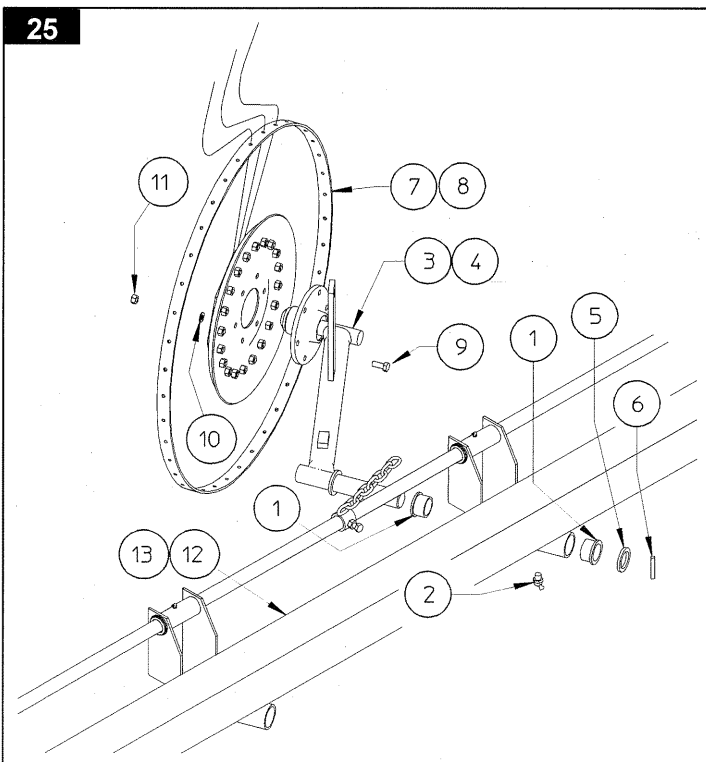

In this step, you will use:

Item 1:

24 - bushings D 35-42 x 26
(D 1" 3/8-1" 11/16 x 1")

Item 2:

12 - bent grease nipples M 6
(15/64")

Item 5:

12 - washers D 35-50 x 5
(D 1" 3/8-2" x 3/16")

Item 6:
12 - spring pins D 8 x 50
(D 5/16" x 2")

Item 9:
60/48 - screws M 10 x 25
(25/64" x 1")

Item 10:
72 - grower washers D 10.5-17 x 2.2
(D 27/64"- 11/16" x 3/32")

Item 11:
72 - nuts M 10
(25/64").

26. CAUTION



NOTE: The spring hook X is more closed than spring hook Y. Hook the 6-7th link of chain 1 on fork assy 2 and then hook it on hook X of spring 3. Hook the 25th link of chain 1 (5th from the

end) on fork assy 2 and the link it into hole J of arms 4 & 5. Hook Y of spring 3 must also be hooked into hole Z of arms 4 & 5 (RH - LH).

NOTE: that given before is a standard regulation of the chain 1

In this step, you will use:

Item 2:
12 - fork assy D 8
(5/16")

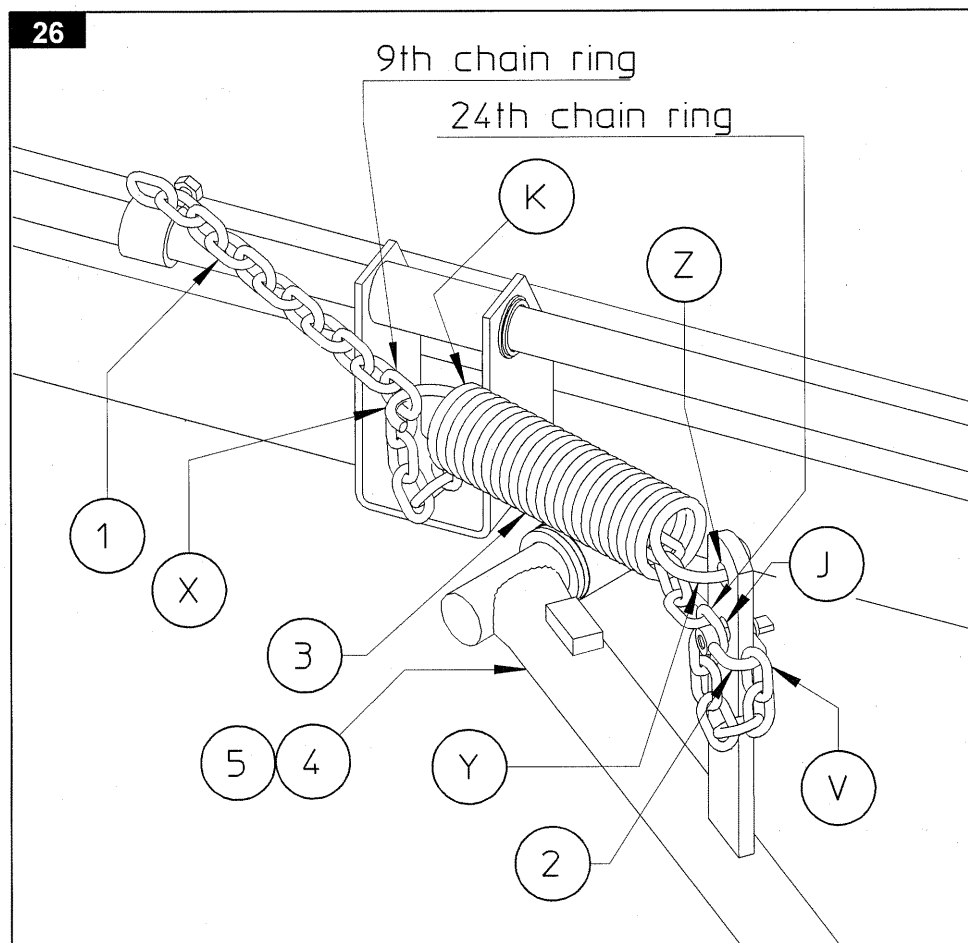

27. ATTENTION

Fit cylinders 4 into the correct places on drawbar 1 and fixed arms 2 & 3 (LH - RH). Fasten cylinders 4 to drawbar 1 with pins 9 and screws 7. Attach grease nipples 8 to pins 9. When screw 11 is fastened, attach self-locking nut 10 to screw 11 as show in figure, to prevent pin 9 to go out if screw 11 is loosened. Fasten cylinders 4 to fixed arms 2 & 3 (LH - RH) with pins 5, washers 6 and screws 7. Attach grease nipples 8 to pins 5.

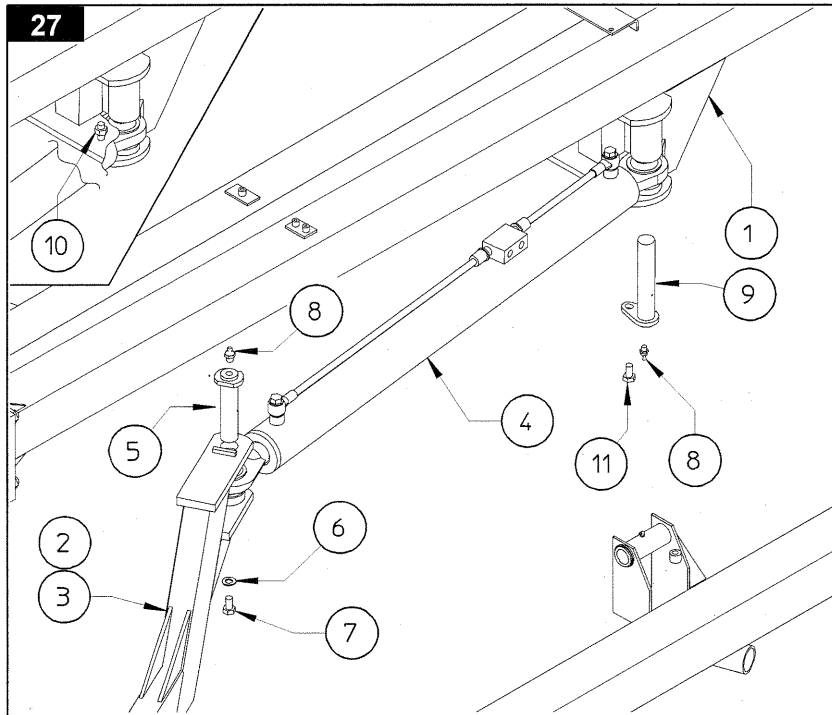

In this step, you will use:

Item 5:

2 - pins D 30 x 122
(D 1" 3/16" x 4" 13/16")

Item 6:

2 - washers D 12-40 x 4
(D 15/32"-1" 9/16" x 5/32")

Item 7:

2 - screws M 12 x 20
(15/32" x 13/16")

Item 8:

4 - grease nipples M 8
(15/16")

Item 9:

2 - pins D 30 x 162
(D 1" 3/16" x 6" 3/8")

Item 10:

2 - self-locking nut M 12-
(D 15/32"--)

Item 11:

2 - screws M 12 x 35
(15/32" x 1" 3/8")

28. CAUTION  RATCHET LINK (OPITIONAL)

Attach the support 2 to the welded plates without tighten the screws 6 and washers 7. Mount the

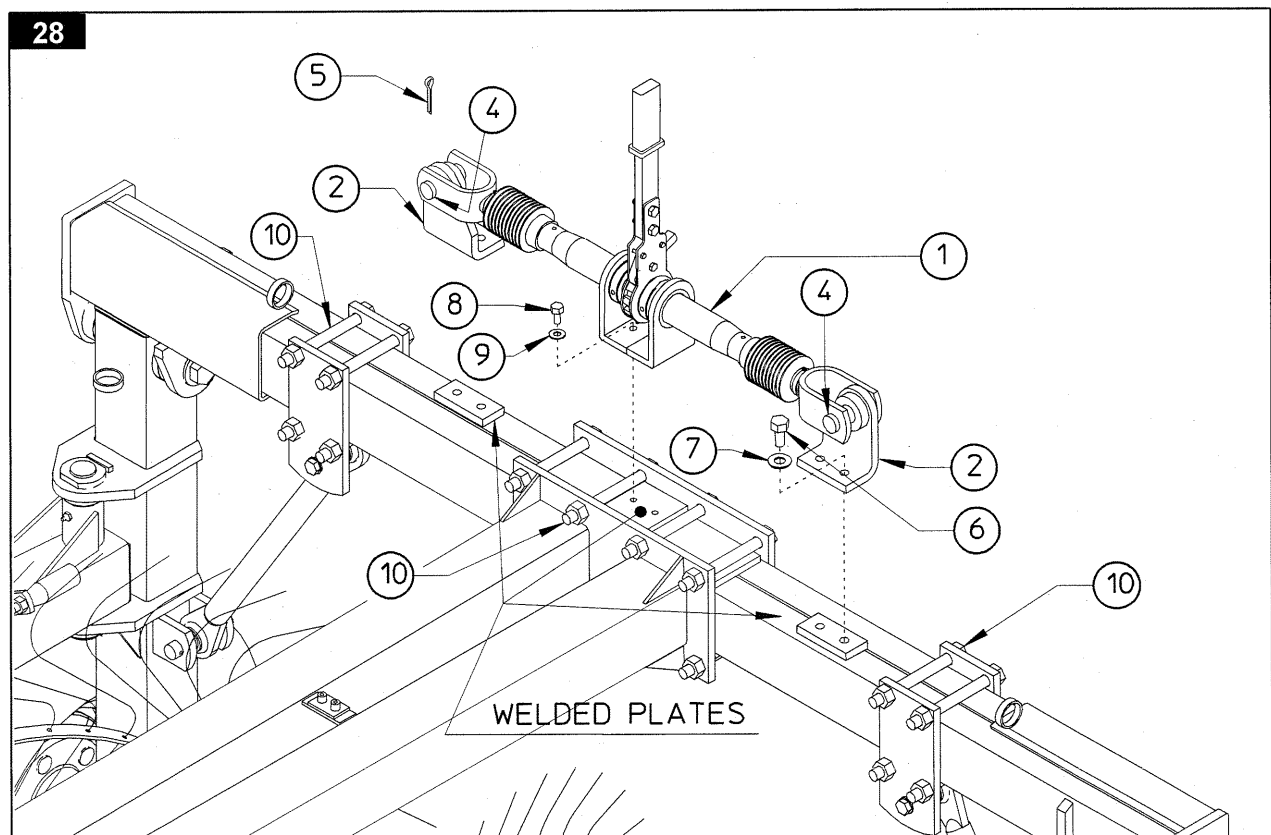

assy 1 to the machine with pins 4 and split pins 5, screws 8 and washers 9. Then tighten the screws 8 and 6.

Item 6:
4 - screw M 14 x 25
(35/64" x 31/32")

Item 8:
2 - screws M 10 x 25
(25/64" x 31/32")

Item 7:
4 - washer D.15
(37/64")

Item 9:
4 - washer D.10,5
(13/32")

REAR OPENING STARTS AT 72" TO A MAXIMUM OF 84" AND THIS ALLOWS TO OBTAIN WINDROWS FROM APPROXIMATELY 3' AND 2" TO A MAXIMUM OF 5' AND 2".

WARNING !!! 

REMEMBER TO LOOSEN THE SCREWS 10 BEFORE USING RATCHET LINK OPENING ONCE ADJUSTMENTS ARE MADE, FASTEN ALL SCREWS 10.

29. CAUTION



Fit the flow divider 1 and the hose collar plate 2 to support A on the drawbar. Fasten in place with screws 3 and nuts 4.

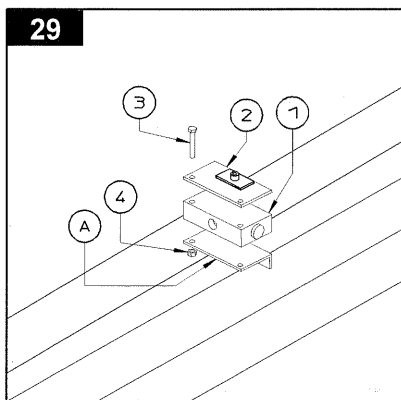

In this step, you will use:

Item 3:
2 - screws M 6 x 60
(15/64" x 2" 13/16")

Item 4:
2 - nuts M 6
(15/64").

30. CAUTION



Attach the eye of hose 1 to hole A of the cylinder valve and fasten it with washers 2 and nipple 3. Attach washer 2 and nipple 5 to the rear of flow divider 4. Connect the curved end of hose 1 to nipple 5. Repeat this step to the other side.

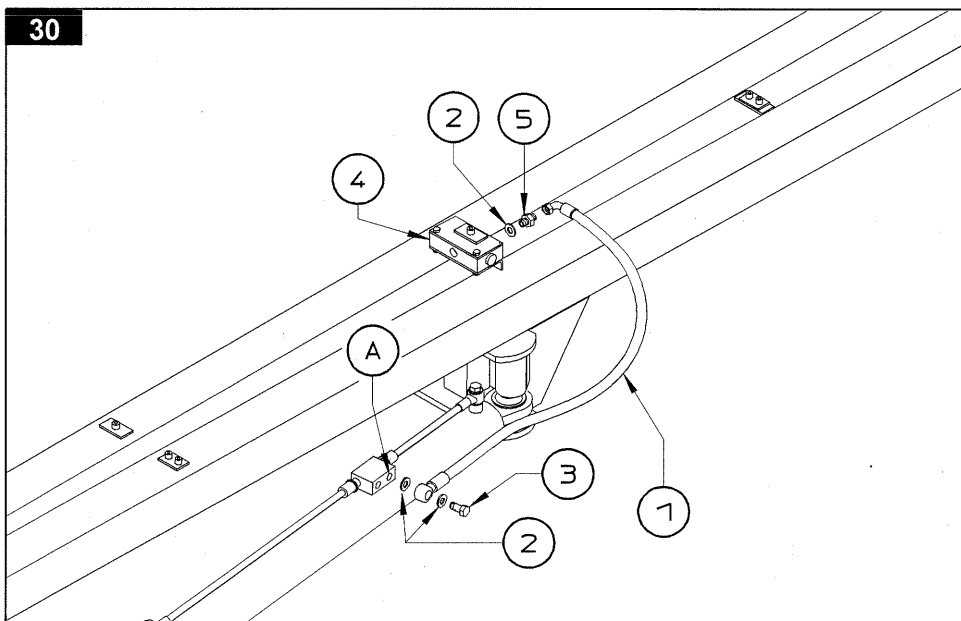

In this step, you will use:

Item 1:
2 - 3/8" hoses, length 720_
(3/8" x 2' 4" 11/32")

Item 2:
6 - copper washers 3/8"

Item 3:
2 - screws 3/8"

Item 5:
2 - nipples 3/8" - 3/8"

31.

**CAUTION**

Attach washers 2 and nipples 3 to cylinders 1. Connect the curved end of hoses 4 to nipples 3.

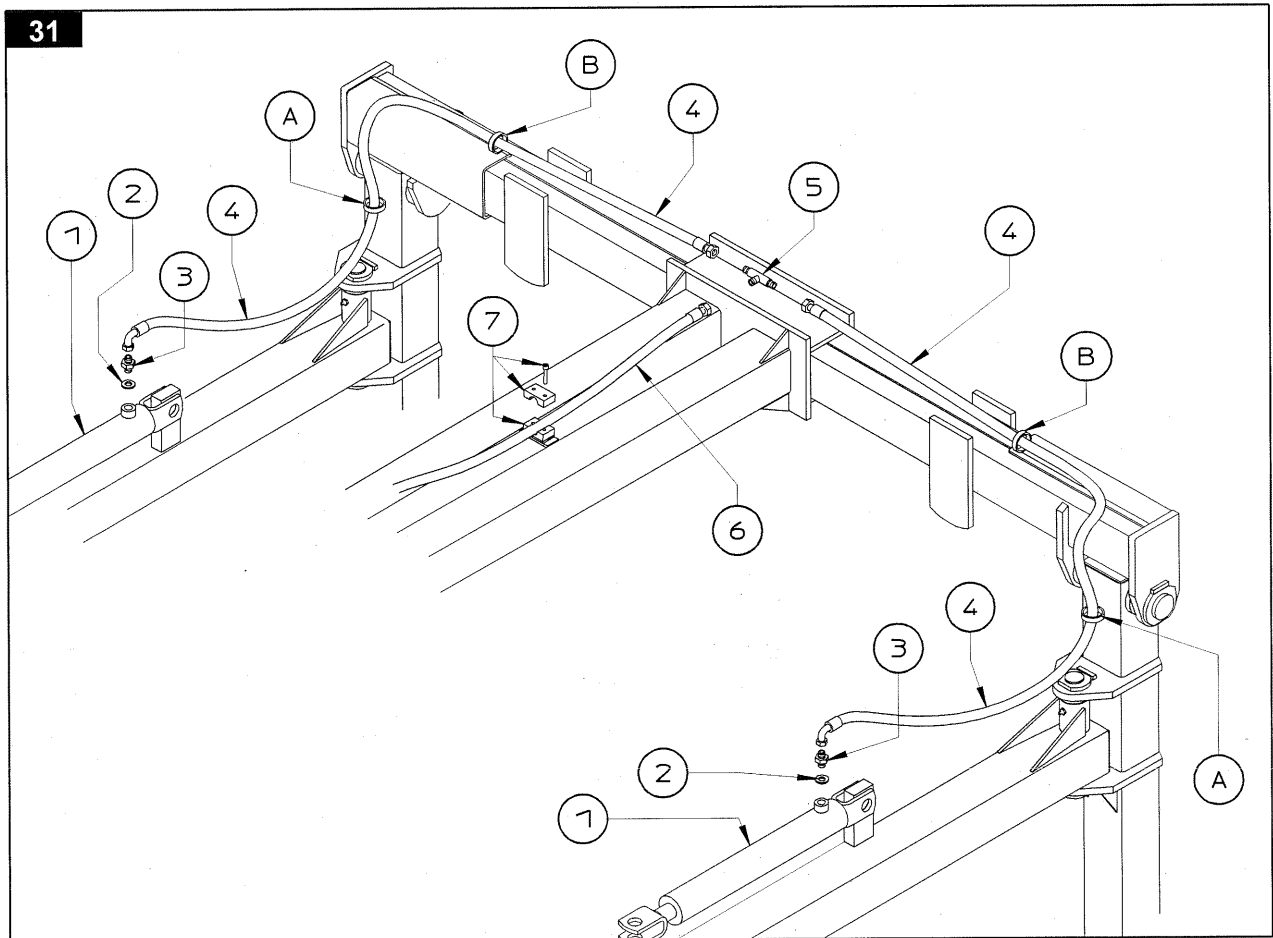

Pass hoses 4 through rings A & B and connect to T connector 5 at the center of the machine. Connect hose 6 to T connector 5 and secure in place with collars 7.
NOTE: Hose 6 will also be in the next few steps.

In this step, you will use:

Item 2:
2 - copper washers 3/8"

Item 3:
2 - nipples 3/8" - 3/8"

Item 4:
2 - 3/8" hoses, length 2060
(3/8" x 6' 9" 3/32)

Item 5:
1 - male T connector 3/8"

Item 6:
1 - 3/8" hose, length 3225
(3/8" x 10' 8")

Item 7:
2 - hose collars D 18
(45/64")

32. CAUTION



Continue to secure hose 6 using collars 5. Attach washer 1 and nipple 2 to hole A in cylinder

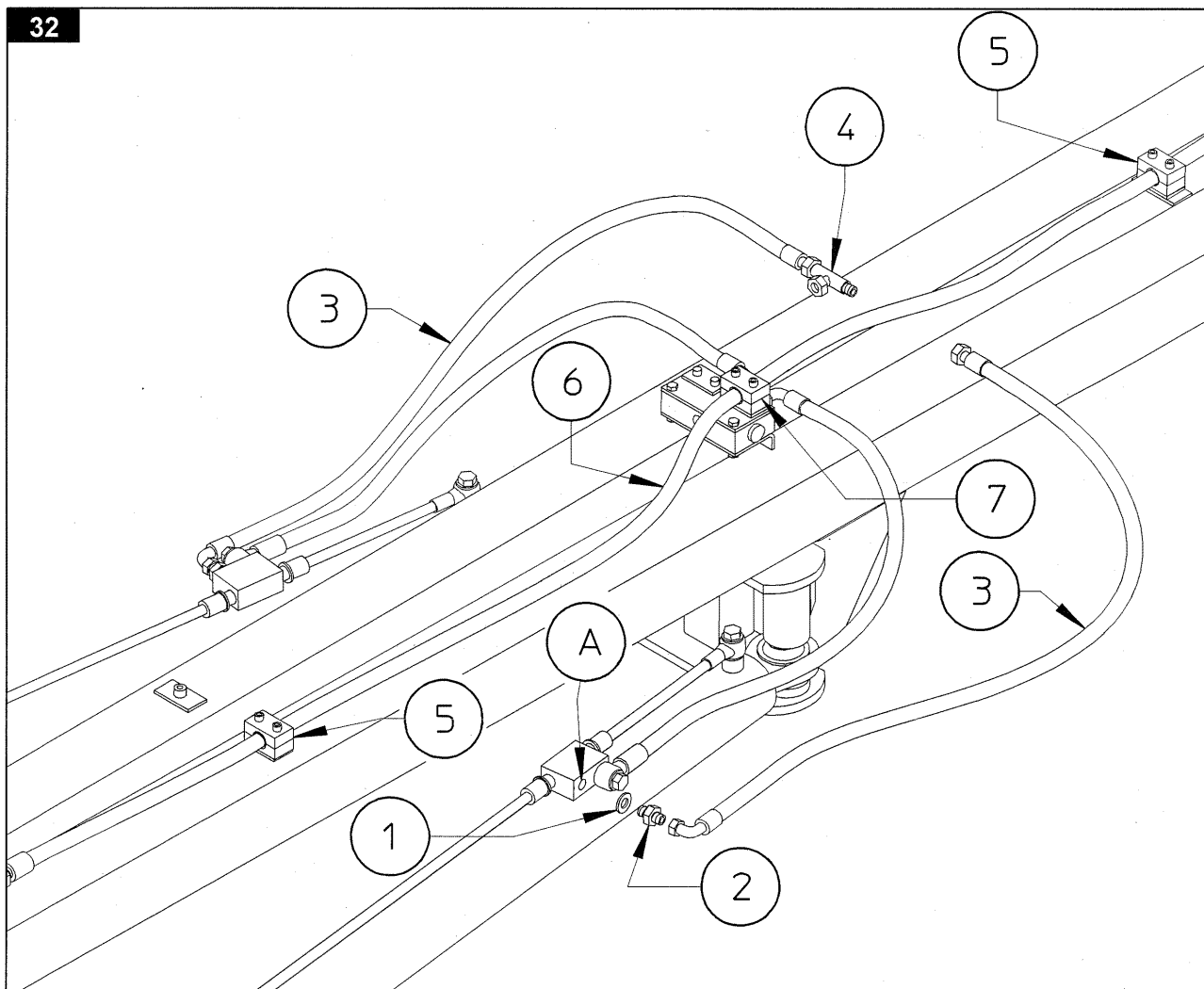

valve. Connect the curved end of hose 3 to nipple 2. Join hoses 3 to T connector 4 at the center of the machine.

Item 4:

1 - male T connector 3/8"

Item 5:

2 - hose collars D 18
(45/64")

Item 6: hose from previous step

Item 7:

2 - double hose collars D 18 (45/64")

33. CAUTION

Screw nipple 1 into hole A of the T connector. Screw hose 2 onto nipple 1. Secure hose 2 in

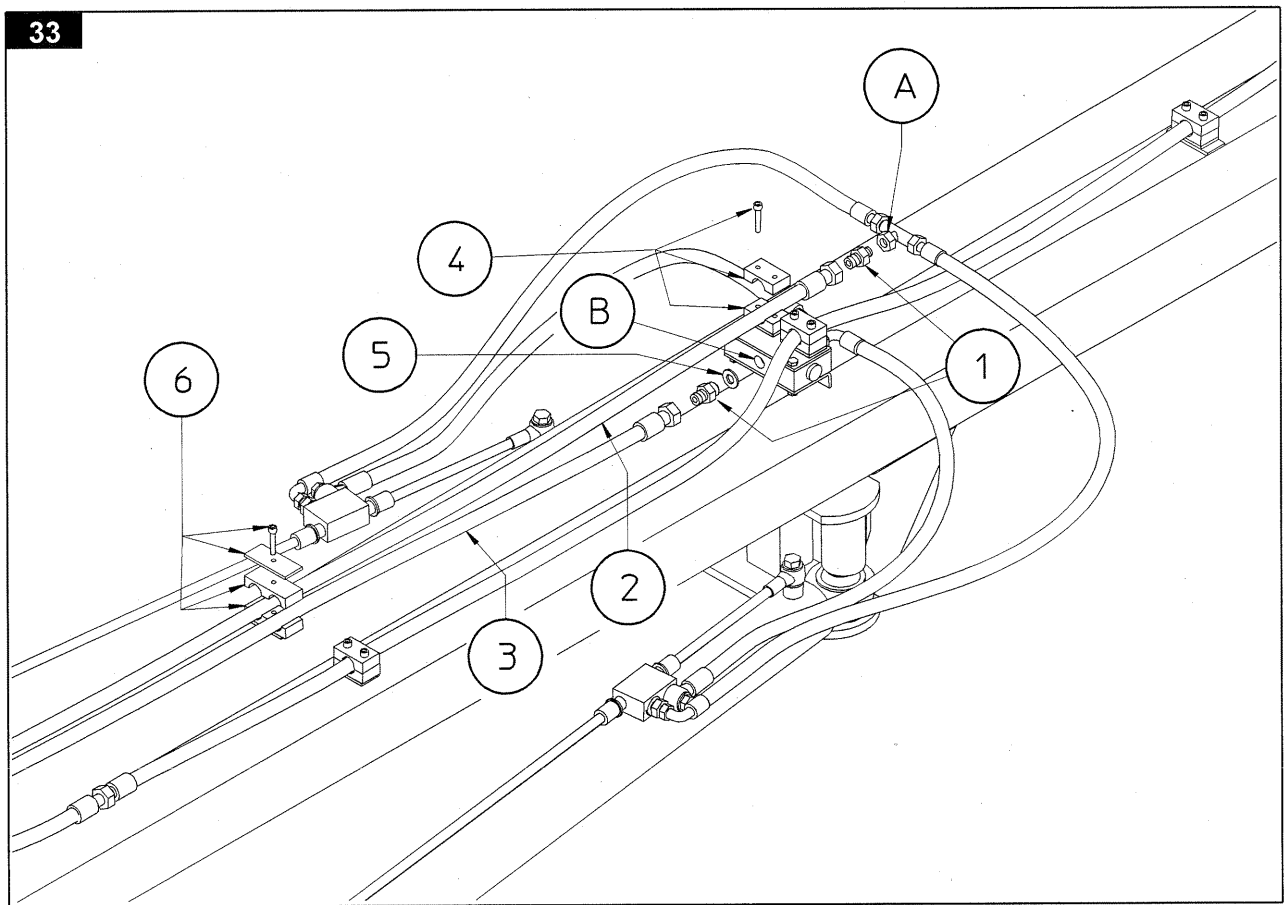

place with collars 4. Screw nipple 1 and washer 5 into hole B of the flow divider. Screw hose 3 onto nipple 1 and secure in place with hose collar 4.

NOTE: Hoses 2 & 3 will also be in the next step.

In this step, you will use:

- | | |
|-----------------------------|------------------------------|
| Item 1: | (3/8" x 20' 11" 61/64) |
| 2 - nipple 3/8" - 3/8" | |
| Item 2: | Item 5: |
| 1 - 3/8" hose, length 6550_ | 1 - copper washers 3/8" |
| (3/8" x 21' 5" 55/64) | |
| Item 3: | Item 6: |
| 1 - 3/8" hose, length 6400_ | 2 - double hose collars D 18 |
| | (45/64") |

34. CAUTION



Pass hoses 2-3-6 through loop A on drawbar 1. Secure hose 6 in the correct places with hose collars 9. Secure hoses 2-3-6 in the correct places with hose collars 7 and with double hose collar 8. Attach washers 4 and quick-release couplings 5 to the ends of hoses 2-3-6.

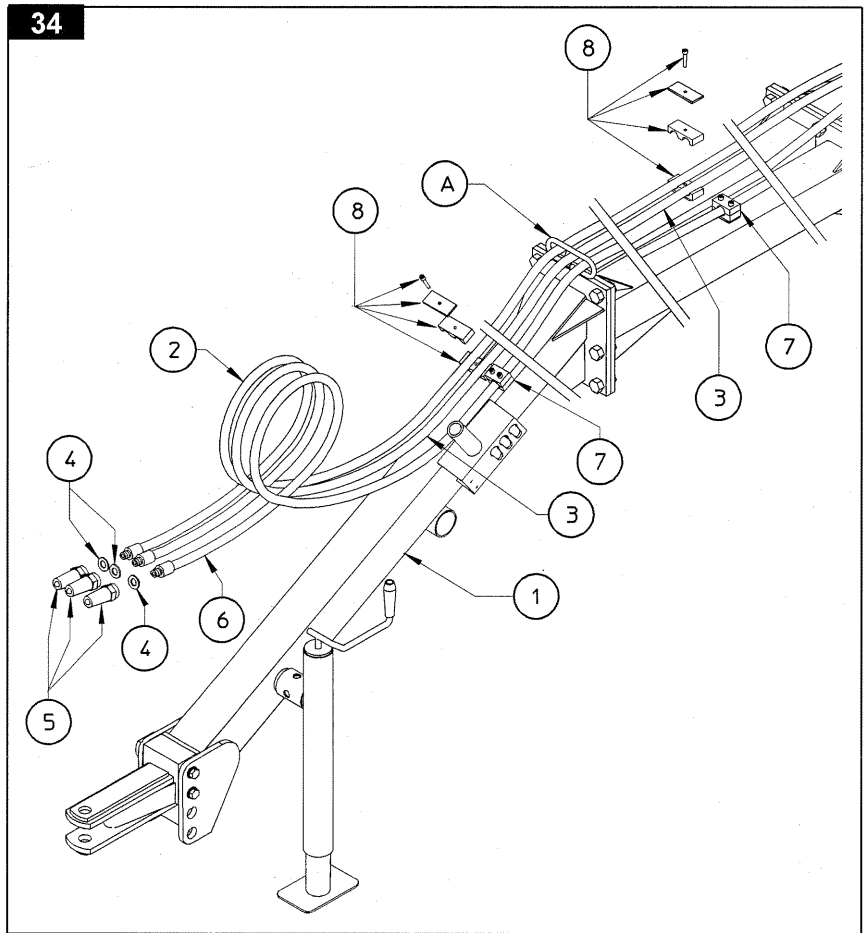

In this step, you will use:
 Items 2-3: hosing from previous steps

Item 4:
 3 - copper washers 1/2"

Item 5:
 3 - quick-release couplings 1/2"

Item 6:
 1 - 3/8" hose, length 5360 (3/8" x 17' 7")

Item 7:
 2 - hose collars D 18 (45/64")

Item 8:
 2 - double hose collar D 18 (45/64")

35.

At this point, the machine is completely assembled. Before testing for operation, it is necessary to

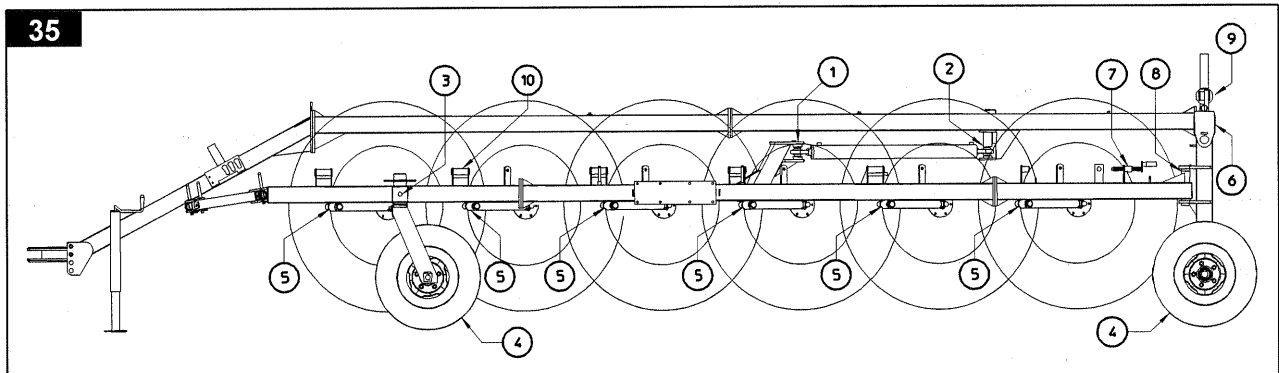

lubricate and check the movement of all parts. This diagram gives the maintenance program, to be carried out in its entirety the first time, and subsequently according to the schedule as shown.

Pos.	Q.ty	Description	Operation	Every x huors	Notes
1	2	Opening cylinder head joints	lubricate	16	
2	2	Opening cylinder foot joints	lubricate	16	
3	2	Front wheel support joints	lubricate	8	
4	4	Tires	check pressure	A	
5	12	Rake wheel bracket joints	lubricate	25	
6	2	Rear wheel supports	lubricate	25	
7	2	Crank screws	clean, lubricate	A	Brush spatula
8	2	Rake wheel section joints	lubricate	8	
9	1	Ratchet link	lubricate	15	
10	12	Rake wheel pipe supports	lubricate	25	
A = every time the part is used					
IMPORTANT					
General checking of bolts, security pins and split pins to be carried out initially after the first 8 huors of use. Subsequently every 50 huors and whenever the machine is laid up for extended periods.					

6. Connection to the tractor and transport

36. DANGER



To connect the machine to the tractor, first it is necessary to raise or lower parking stand 1 so that drawbar 2 is parallel to the ground. Back the tractor up to the machine and look to see if hitch 3 is aligned with tractor hitch 4. If hitch 3 is much higher or lower than tractor hitch 4, it is necessary to change the position of hitch 3 by choosing the holes in plate 5 which give the best alignment. At this point connect hitch 3 to tractor hitch 4 using a suitable pin. Next turn the parking stand crank to retract the base of the stand.

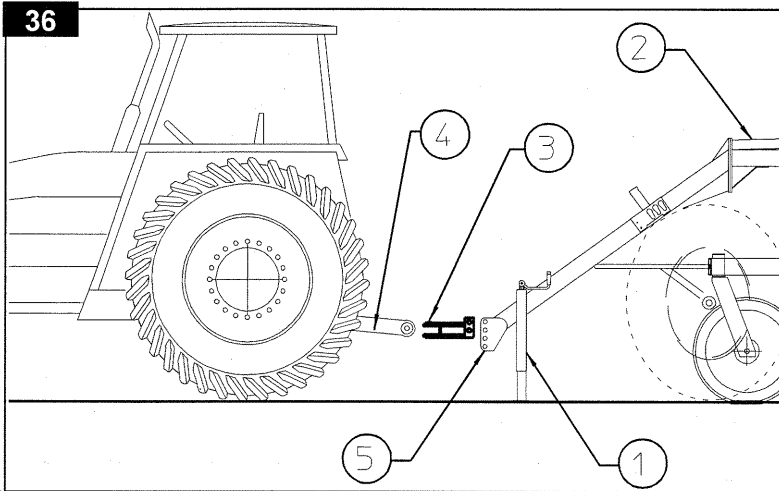

37. CAUTION



Parking stand 1 should be removed from the parking position indicate in figure 23 and attached to bushing 4 as in figure. This is done by removing clip 3 and pin 2 and moving stand 1 out of the parking position and pasten parking stand 1 into the transport position using pin 2 and clip 3 as indicated .

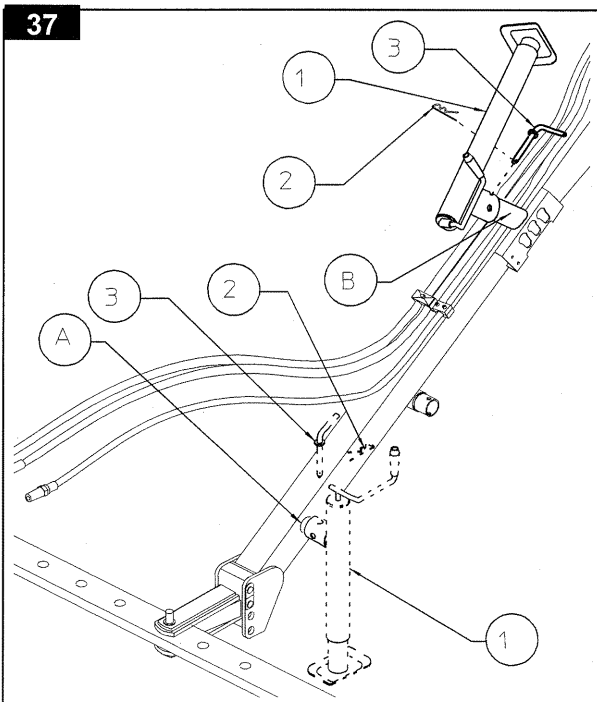

38. CAUTION 

At this point the quick-release couplings of hoses 1-2-3 should be attached to the relative tractor couplings 4-5-6. The movements of the machine are now controlled by operating levers A & B. Hoses 1 & 2, connected to couplings 4 & 5, control the cylinders for opening the machine. Hose 3, connected to coupling 6, controls the cylinders for lifting the rake wheels. It is recommended that all movements be repeated a few times to eliminate air from the system. The machine is now ready for operation.

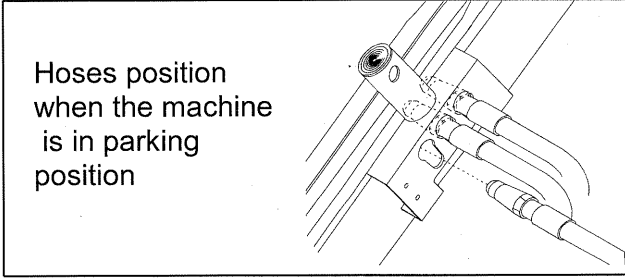
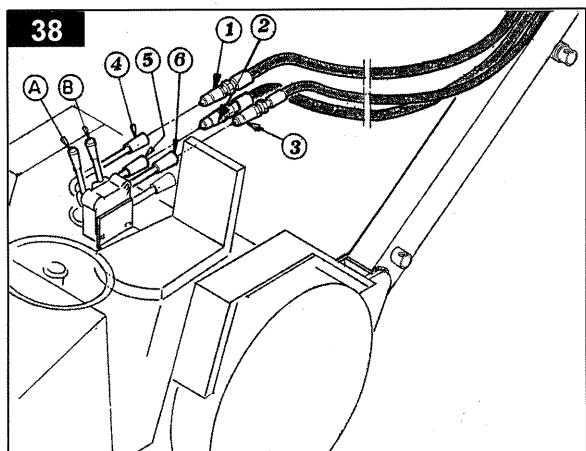

39. CAUTION 

During transport it is necessary to move pin 1 and clip 2 from position A to position B. This removes the load from the rake wheel lifting cylinders.

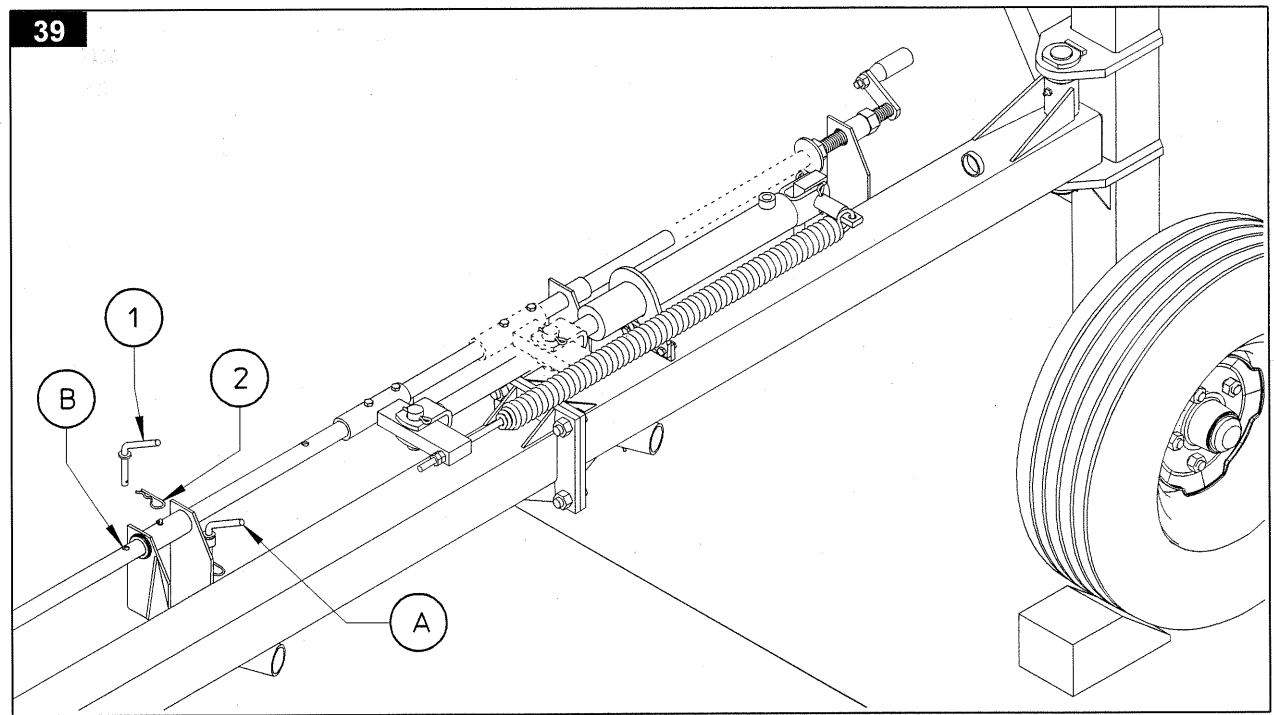

In this step, you will use:

Item 1:
2 - pins D 10 x 63 (D 25/64" x 3" 30/64")

Item 4:
2 - clips D 3 (D 1/8")

40. CAUTION



At this point it is necessary to attach the transport arms. Insert arm 1 in arm 2 and lock in place with pin 3 and clip 4. The transport arm assembly is then attached by placing the fork of arm 1 on attachment A of the drawbar and the fork of arm 2 on the rake wheel section.

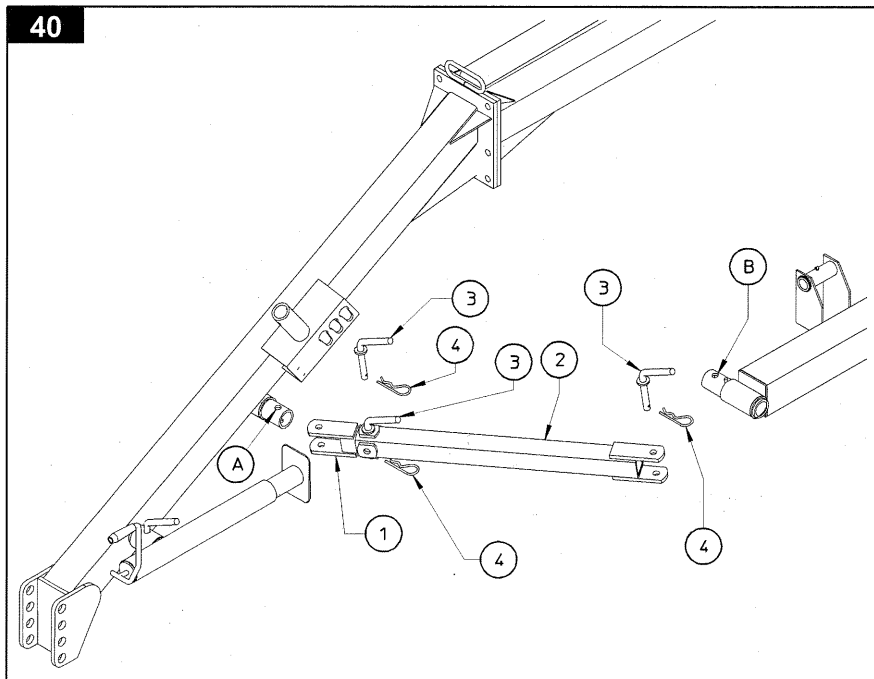

Fasten with pins 3 and clips 4. The transport arm assembly is then attached by placing the fork of arm 1 on attachment A of the drawbar and the fork of arm 2 on the rake wheel section.

Fasten with pins 3 and clips 4.

In this step, you will use:

Item 3:
6 - pins D 15 x 95
(D 19/32" x 3" 47/64")

Item 4:
6 - clips D 3 (D 1/8")

7. General instructions for field use

41. CAUTION



The first thing to be done in the field is to remove transport arms 1 & 2, replacing pins 3 in holes A & B and fastening them with clips 4. The transport arm assemblies are to be placed over pins C & D on the rake wheel sections as shown. Paste the transport arms to pins C & D with clips 5.

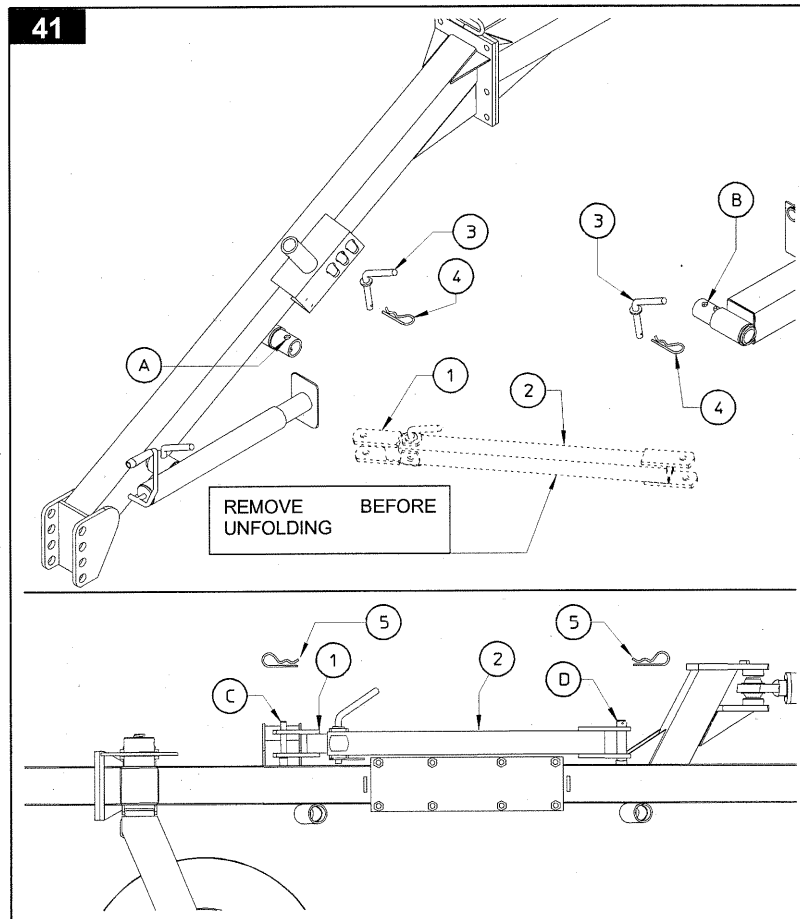

In this step, you will use:

Item 5:
4 - clips D 3
(D 1/8").

IMPORTANT

Before starting raking operation make sure that the transport lock arms have been removed from the transport position and set in working position.

Transport lock arms cannot be used to lock one raking wing, R.H. or L.H in order to work on one side only because this is not allowed.

By operating the opening cylinders the machine is opened to the fully open position. If work must be done on particularly uneven ground, do not operate in the fully open position. Open the machine so that the working width is at most 3' narrower than the fully opened position.

42. CAUTION



Remove clip 2 and pin 1 from position A and fasten them in position B. Operate cylinders 3 to lower the rake wheels.

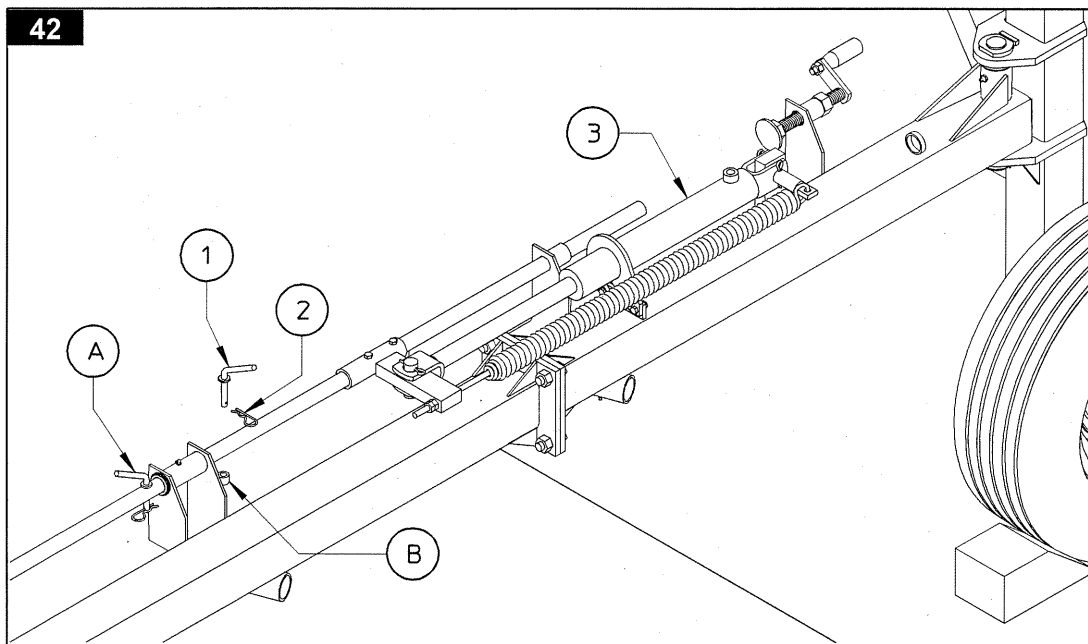

43. CAUTION



Adjust rake wheel pressure on the ground by turning crank 1. Normally the rake tines should brush the ground. When properly adjusted, tighten nut 2 to lock the screw of lever 1 in place.

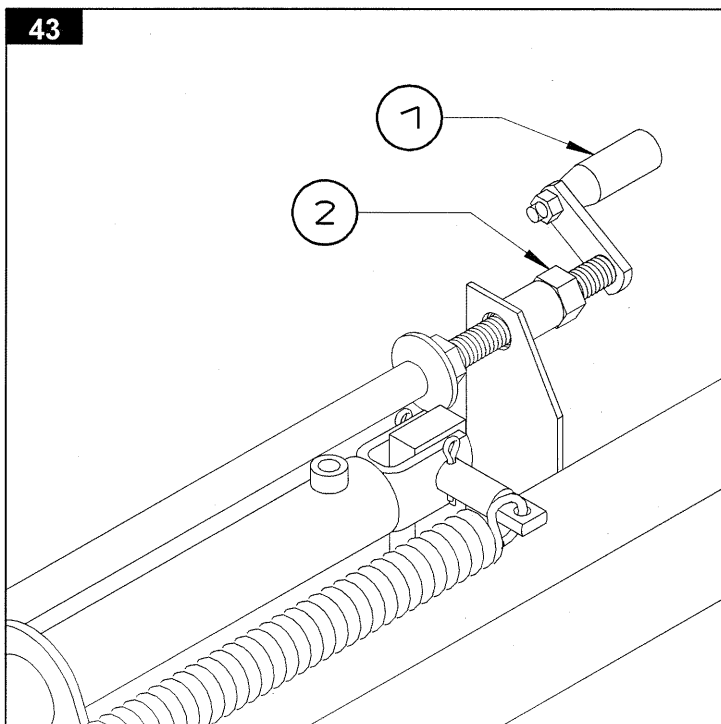

44. CAUTION



REAR OPENING

Loosen all screws which fasten the plates 2 and the counterplate 1. Pull out the cross member 3 &

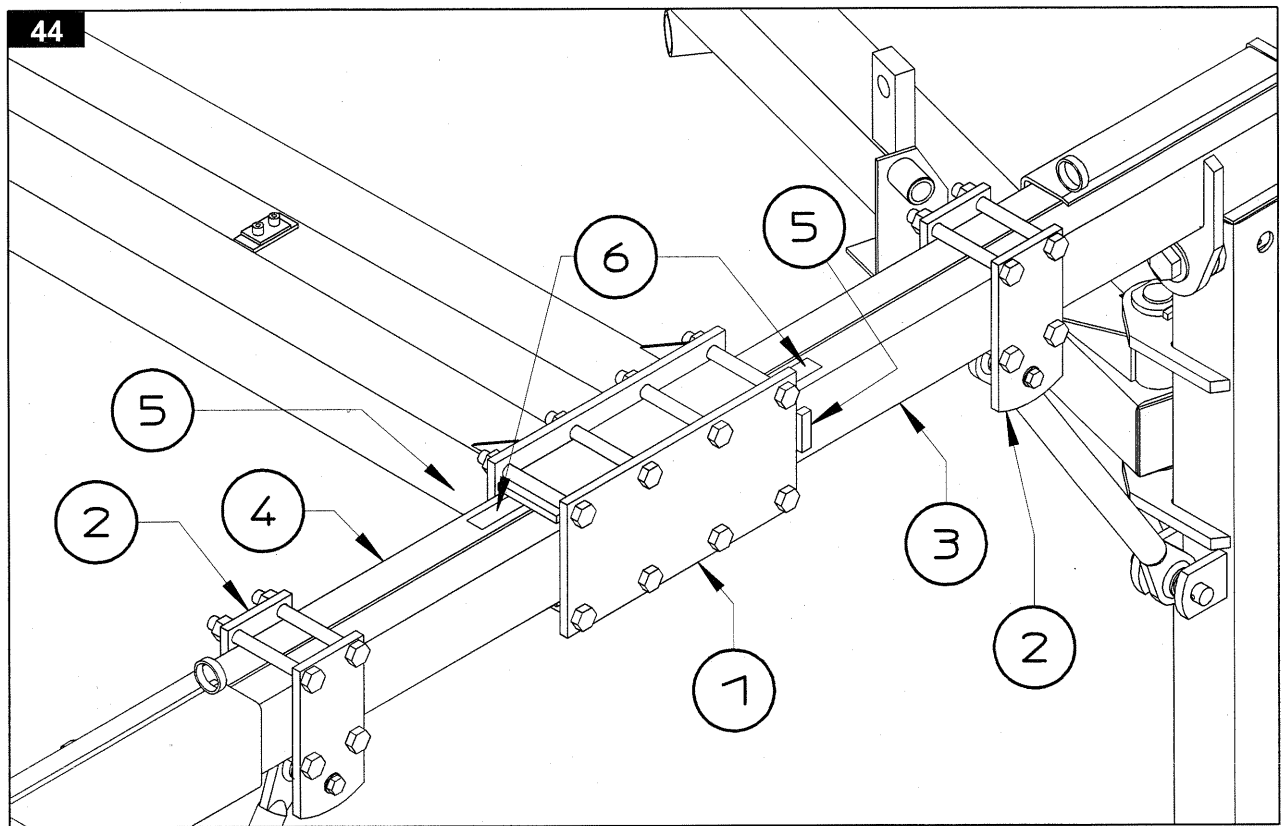

4 paying attention on ledges 5 welded on cross member 3 & 4. The distances must be read from label 6. The distances of cross members 3 & 4 must be the same. Once adjustments are made, fasten all screws of plates 2 and counterplate 1.

NOTE: Cross members 3 & 4 must be opened the same amount keeping in this way the drawbar in the middle of the machine.

REAR OPENING STARTS AT 72" TO A MAXIMUM OF 84" AND THIS ALLOWS TO OBTAIN WINDROWS FROM APPROXIMATELY 3' AND 2" TO A MAXIMUM OF 5' AND 2".

NOTE : These measures are approximate and vary due to the type of forage, conditions of the forage (whether it is more or less dry) and the type of ground.

45. **CAUTION**  **REAR OPENING with RATCHET LINK (OPTIONAL)**

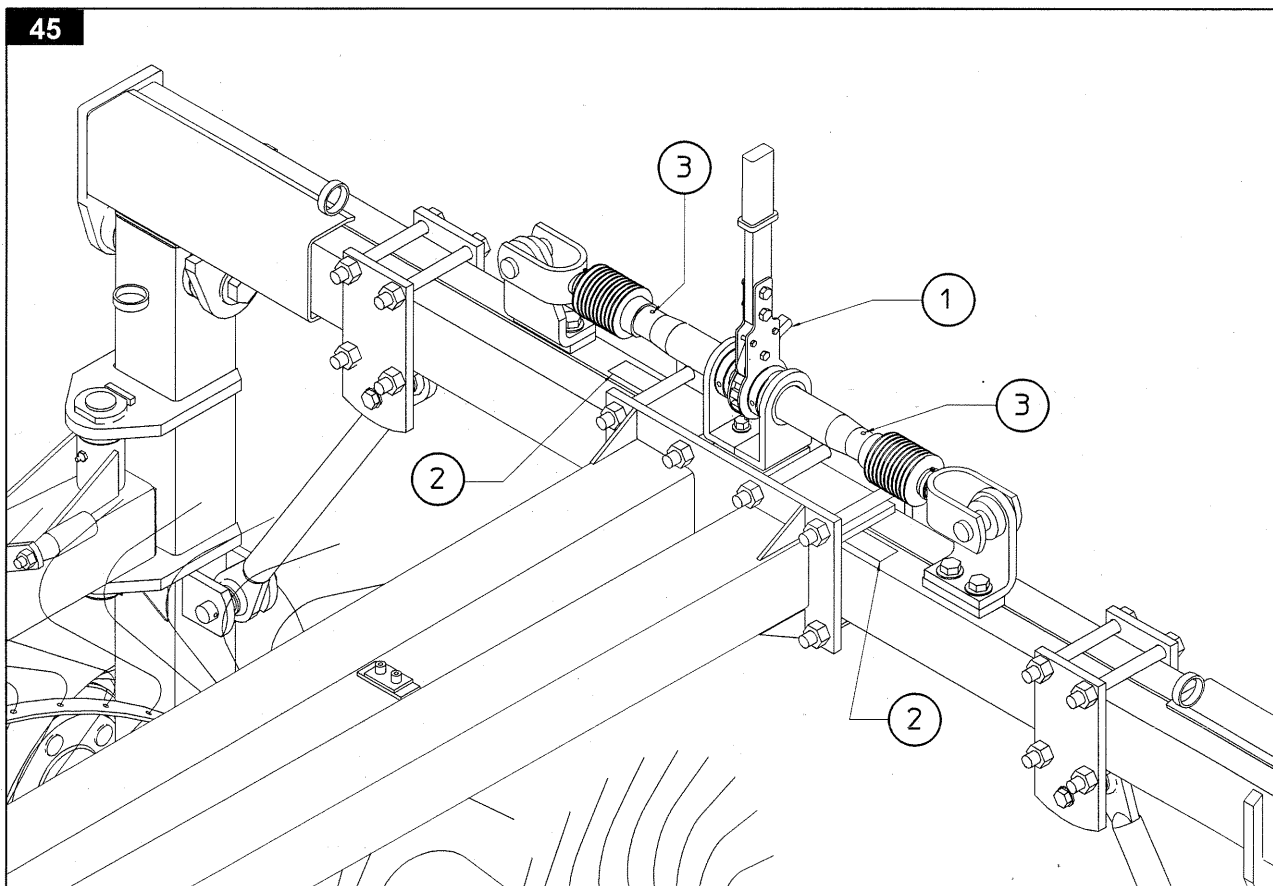

REAR OPENING STARTS AT 72" TO A MAXIMUM OF 84" AND THIS ALLOWS TO OBTAIN WINDROWS FROM APPROXIMATELY 3' AND 2" TO A MAXIMUM OF 5' AND 2".

NOTE : These measures are approximate and vary due to the type of forage, conditions of the forage (whether it is more or less dry) and the type of ground.

WARNING !!! 

REMEMBER TO LOOSEN ALL SCREWS WHICH FASTEN THE PLATES 2 AND THE CONTERPLATE 1 IN FIG.46 BEFORE USING RATCHET LINK OPENING
Once adjustments are made, fasten all screws.

Use hook 1 to open or to reduce the windrows .
 Labes 2 give the measure of windrows (inches).
 Lubricate using greasenipples 3 (see table pag.37)

8. General maintenance instructions

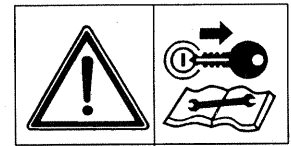
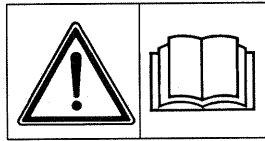
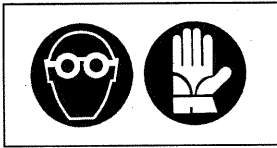

8.1 Repair work

Any repair work must be carried out with the machine at rest and disconnected from the tractor. Do not carry out welding without authorisation and instructions from the manufacturers. Disconnect the machine from the tractor before any welding work in order not to damage the battery. Always use a protective mask, goggles and gloves when welding, sanding or grinding or when using a hammer or drill.

Always work on the machine out of doors. If you have to operate the machine when connected to the tractor in an enclosed area (for example when testing after repair and/or maintenance), ensure that there is sufficient ventilation so as to prevent noxious exhaust gases accumulating. In order to acquire the necessary control and to operate in safety, practise various manoeuvres by simulating those required in the workplace with the help of an experienced person.

8.2 Laying up for extended periods

At the end of the season, or when an extended period of inactivity is envisaged, it is advisable to:

- 1) clean the machine following instructions and allow it to dry;
- 2) check it carefully and replace any damaged or worn parts;
- 3) thoroughly tighten all screws and bolts;
- 4) grease the machine thoroughly and then cover it completely and lay it up in a dry place.

It is to the users advantage to carry out these operations carefully. In this way, he will have a machine in perfect condition when work is restarted.

On restarting work, repeat all the proper checks so as to be certain of working in conditions of maximum safety.

IMPORTANT

During extended periods of inactivity it is necessary to close completely the cylinders. This must be done in such a way as to protect the rods from weather effects.

The rods parts remaining outside the cylinder pipe (whatever reasons may be) must be carefully protected with a grease layer.

8.3 Maintenance direction

All cleaning, lubrication and maintenance operations must be carried out with the machine disconnected from the tractor.

In an emergency with the machine still connected to the tractor, switch off the engine, apply the parking brake, and remove the ignition key from the instrument panel.

Regular, correct maintenance and proper operation are the basic prerequisites for the long-term efficiency and safe operation of the machine.

Pay special attention to all instructions given on signs located on the machine.

All maintenance should be carried out in an area having the proper equipment readily available and in good condition. This area must always be kept clean and dry and must have enough surrounding space to facilitate operations.

Any work must be carried out by trained personnel. Contact the dealer nearest to you.

Respect the warnings and procedure for maintenance and technical assistance given in this manual.

Do not use petrol, solvents or other flammable liquids as detergents.

Use commercial non-flammable and non-toxic solvents, authorised by competent bodies.

Do not use compressed air or water at high pressure to clean the machine. If this is unavoidable, then wear goggles with side protection and limit the pressure as much as possible. When the work is finished, and with the machine disconnected from the tractor, inspect and check the machine completely.

THE FOLLOWING SHOULD BE NOTED IF THE MACHINE IS SCRAPPED:

The machine consists mainly of ferrous material which must be disposed of according to the regulations in force in the country concerned.

There is also a small amount of plastic which must be disposed of according to the regulations in force in the country concerned.

9. Central wheels kit: instructions for installation

9.1

This is the diagram for positioning the various components of the central rake wheel kit.

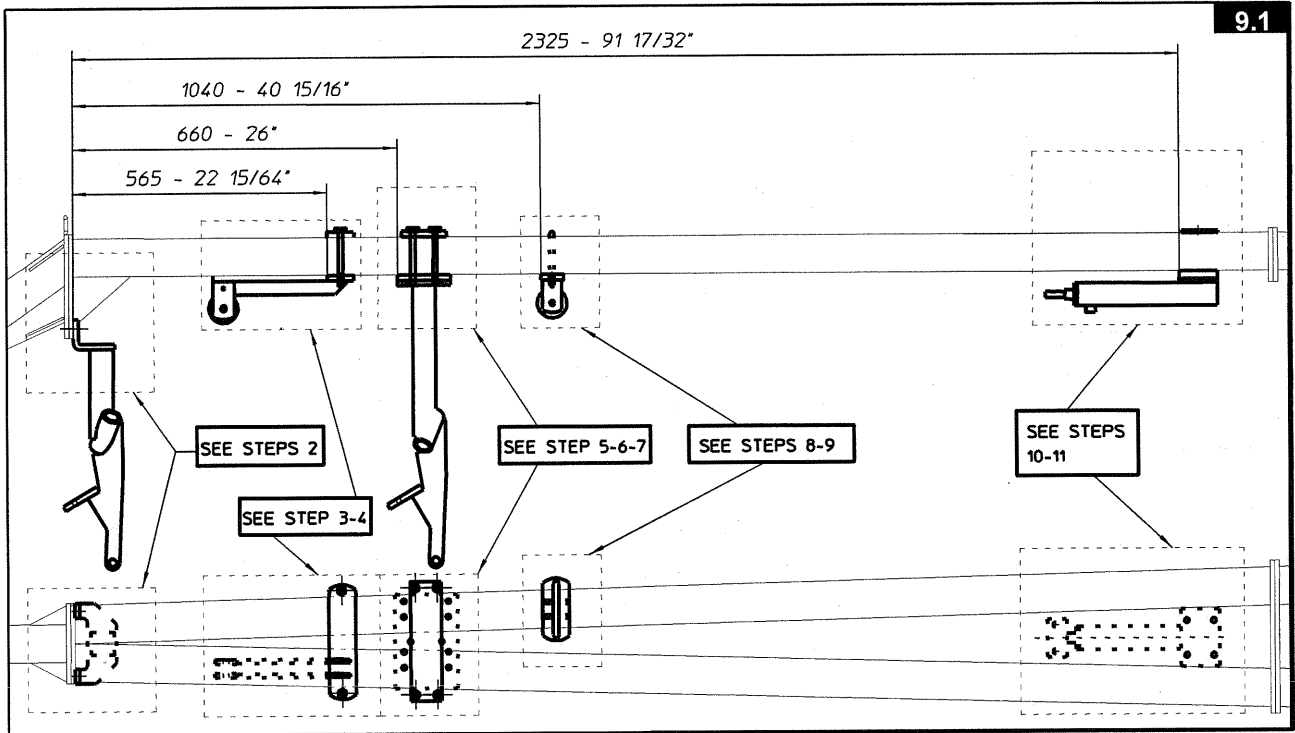

9.2

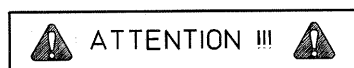

First of all remove the two screws of position "A" Attach support 1 to plate front drawbar using screws 2 and nuts 3.

In this step, you will use:
 Item 2: 2 screws M16 x 60
 (5/8" x 2 3/8")
 Item 3: 2 nuts m16 (5/8")

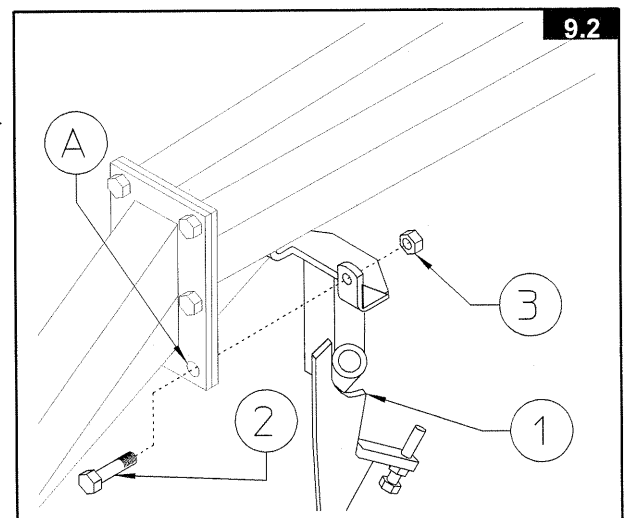

9.3



Mount pulley 1 and bush 2 into bracket 3 using special screws 4 and nuts 5.

In this step, you will use:

Item 4: 1 special screw M12x70
(1/2" x 2 3/4")

Item 5: 1 nut M12 (1/2")

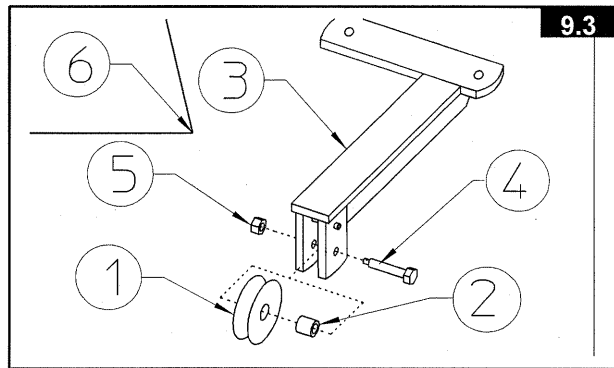

9.4

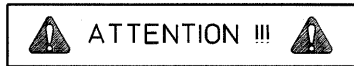

Place the pulley support 6 against the lower part of the drawbar and fasten it with screws 1, washers 2 and nuts 3.

For positioning, see point 1.

In this step, you will use:

Item 1: 2 screws M12x140
(15/32"x5 1/2")

Item 2: 2 washers $\varnothing 13$ ($\varnothing 1/2$ ")

Item 3: 2 nuts M12 (1/2")

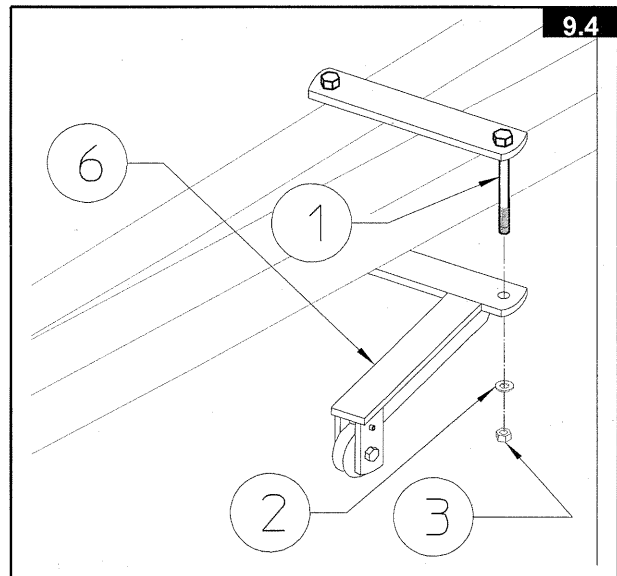

9.5

Plate 1 has the A-A1 and B-B1 pairs of holes that allow adjustment of the rake wheel position.

We recommend fastening support 2 (see point 7) to the B-B1 pairs of holes.

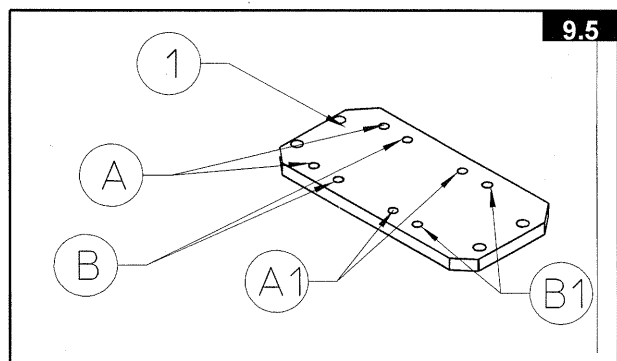

9.6



Place plate 1 against the lower part of the drawbar and fasten it with counterplate 2, screws 3 and nuts 4.

For positioning, see point 1.

Note : the B1 pair of holes should be positioned as shown in the drawing.

In this step, you will use:

Item 3: 4 screws M12 x 140
(15/32" x 5 1/2")

Item 4: 4 nuts M12 (15/32")

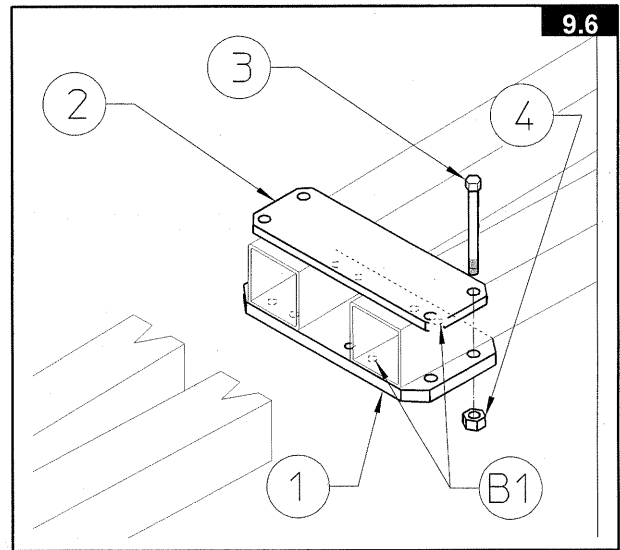

9.7



Attach support 2 to plate 1 using washers 3 - 4 and screws 5.

In this step, you will use:

Item 3: 4 washers $\varnothing 13$ ($\varnothing 1/2$ ")

Item 4: 4 spring washers $\varnothing 13$
($\varnothing 1/2$ ")

Item 5: 4 screws M12x25
(1/2" x 1")

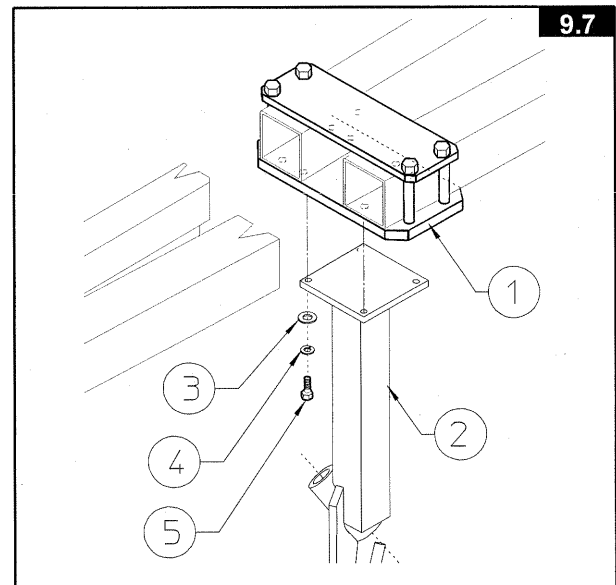

9.8



Mount pulley 1 and bush 2 into bracket 3 using special screws 4 and nuts 5.

In this step, you will use:

Item 4: 1 special screw M12x70
(1/2" x 2 3/4")

Item 5: 1 nut M12 (1/2")

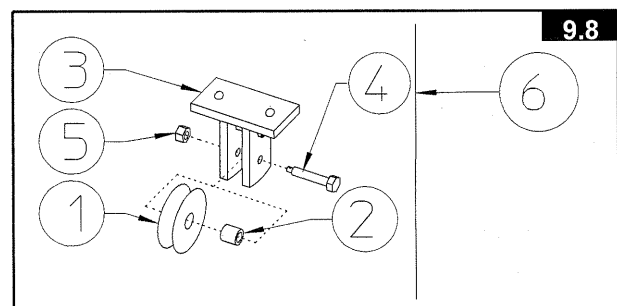

9.9

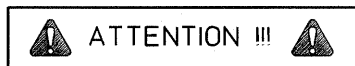

Place the pulley support 6 against the lower part of the drawbar and fasten it with U bolt 1, washers 2 and nuts 3.

For positioning, see point 1.

In this step, you will use:

Item 2: 2 washers $\varnothing 13$ ($\varnothing 1/2$ ")

Item 3: 2 nuts M12 ($5/8$ ")

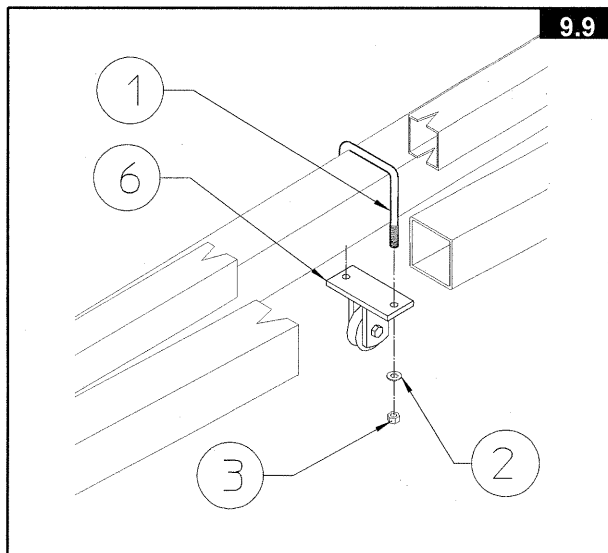

9.10

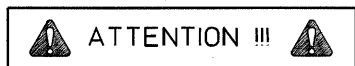

Place plate 1 against the lower part of the drawbar and fasten it with counterplate 2, washers 3 and screws 4.

For positioning, see point 1.

In this step, you will use:

Item 3: 2 spring washers $\varnothing 17$ ($\varnothing 11/16$ ")

Item 4: 2 screws M16 x 130 ($5/8$ " x $5 1/8$ ")

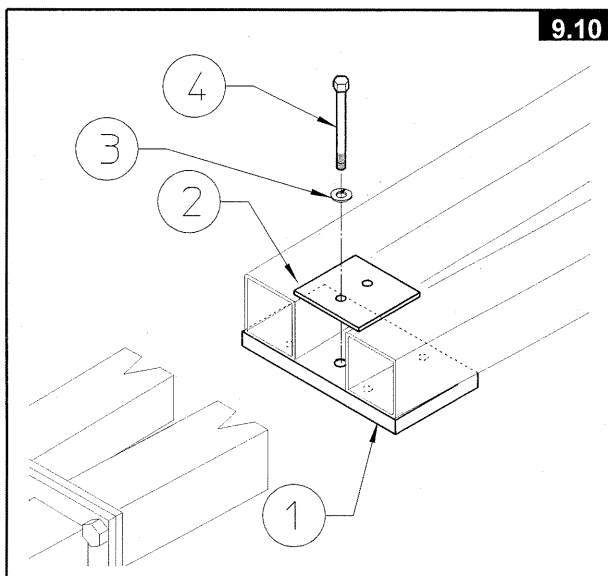

9.11

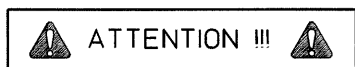

Fasten cylinder 2 to plate 1 using washers 3 and screws 4.

In this step, you will use:

Item 3: 4 spring washers $\varnothing 13$ ($\varnothing 1/2$ ")

Item 4: 4 screws M12x30 ($1/2$ " x $1 3/16$ ")

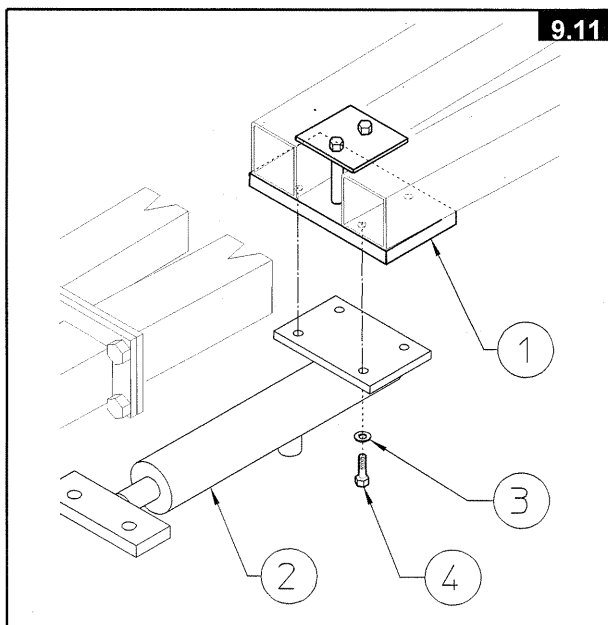

9.12

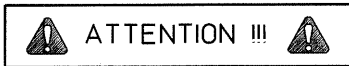

Fasten hose 1 to cylinder 2 using copper washer 3 and nipple 4. Connect "T" connector 5 between the two hoses as shown in the drawing. Connect the hose 1 to "T" connector 5.

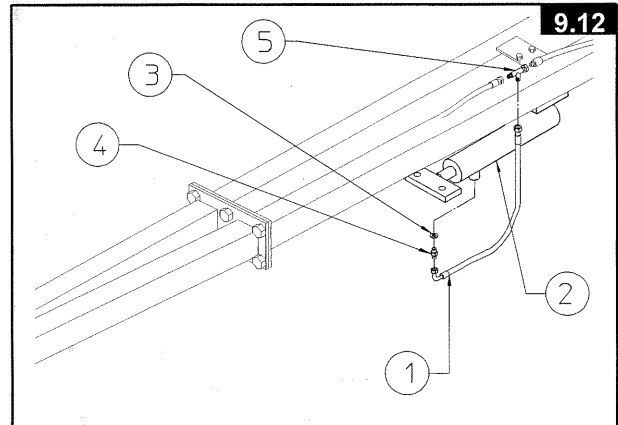

In this step, you will use:

Item 1: 1 hose (3/8") length 480 (3/8" x 19")

Item 3: 1 copper washers 3/8"

Item 4: 1 nipple 3/8"

9.13

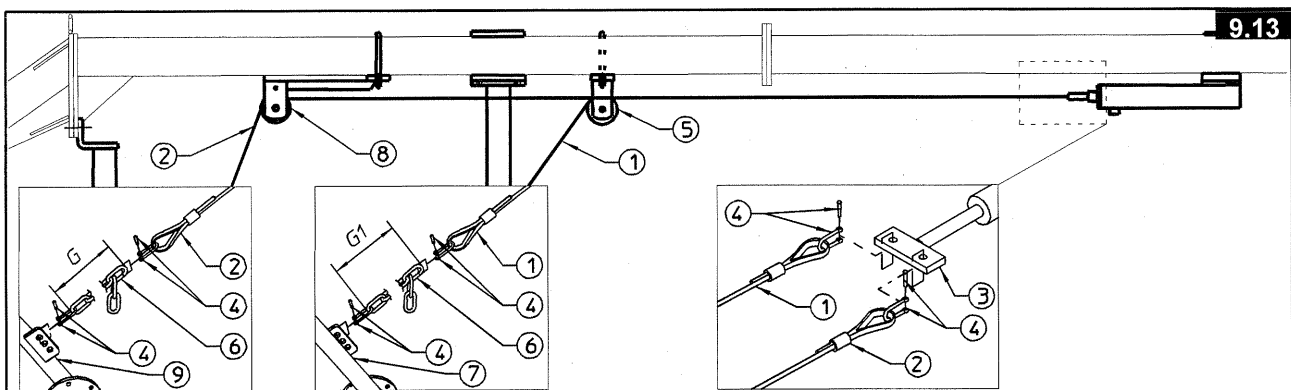

Fit cables 1-2 to cylinder 3 by using clamps 4.

Insert cable 1 on pulley support 5.

Fit chain 6 to rear wheel support 7 by using clamp 4.

Connect to indicated rate chain 6 to cable 1 by using clamp 4.

Item 2: 1 cable length 1730 (68 7/64")

Item 4: 6 clamps 5/16"

Item 5: 2 chain length 280 (11")

Note : G = N° 2 rings of chain
G1= N° 2 rings of chain

In this step, you will use:

Item 1: 1 cable length 1000 (39 21/64")

9.14

Mount rake wheels 1-2 to rake wheel arms 3-4 and fasten with screws 5, grower 6 and nuts 7.

In this step, you will use:

Item 5: 12 screws M10 X 25 (2/64" x 1")

Item 6: 12 growers $\varnothing 10.5-17 \times 2.5$ ($\varnothing 27/64"-11/16" \times 3/16"$)

Item 7: 12 nuts M10 (25/64")

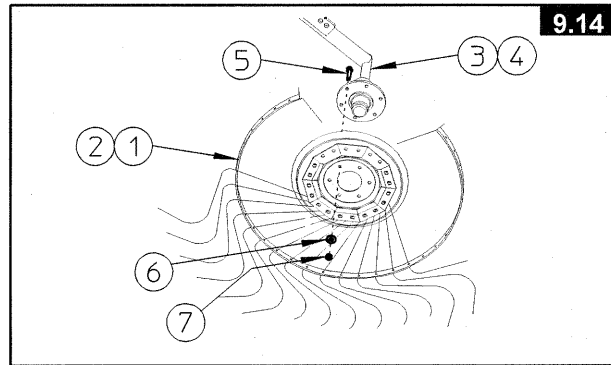

10. Central wheels kit: adjustment for use

So far we have described how to assemble the central rake wheel standard kit. Should the operator feel the operational results unsatisfactory, we now describe points where adjustments can be made.

10.1

In order to improve lift, the rake wheels can be moved backwards or forwards compared with the position shown at point 1 and the pulley support 1-2.

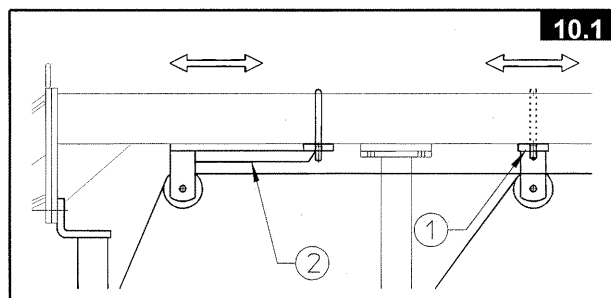

10.2

The adjusting screw 1 can be used to improve both lift and/or pressure of the rake wheels on the ground. Either of the holes 2 in the arms 2-3 (front-rear) can be used and a different ring in chain 7 from the one shown in point 13 can be attached to cables 5-6 (front-rear).

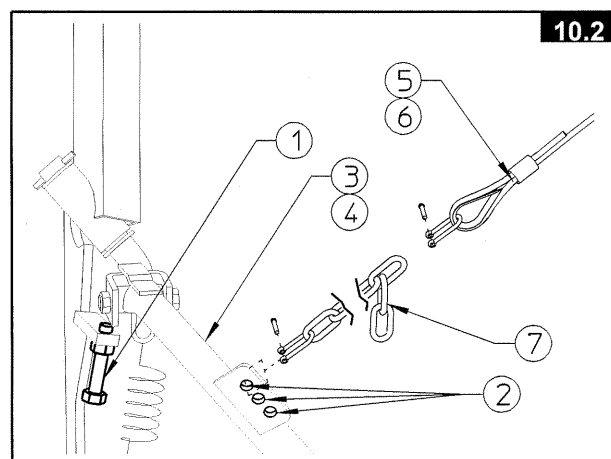

10.3

In order to increase and decrease interference between the side-delivery rake wheels, various positions can be selected to fasten the rake wheel holder supports (see point 7)

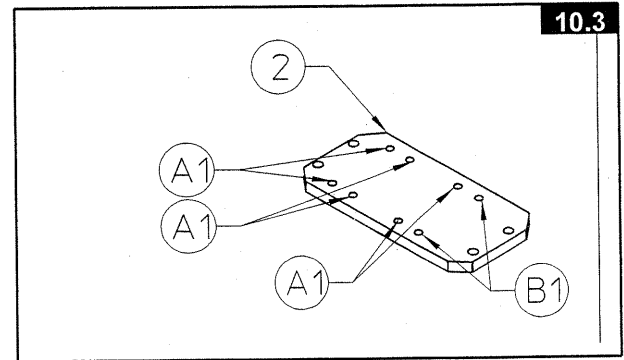

10.4

In order to ensure that the rake wheels are not lowered during transport, hook chain 1 on to pin 2 and block the cotter pin 3.

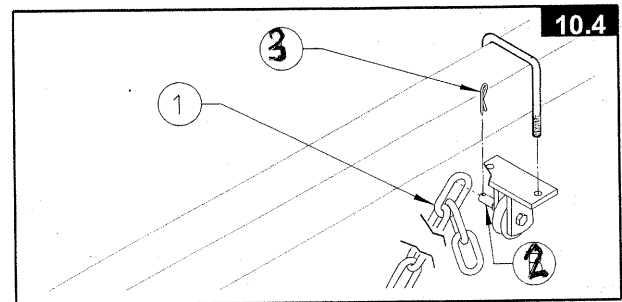

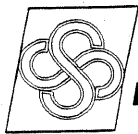

AGRICULTURAL MACHINERY
sitrex®

Zona Industriale-Viale Grecia, 8
06018 TRESTINA-(Perugia)-ITALY
Tel. +39.075.8540021-Telefax +39.075.8540523
e-mail: sitrex@sitrex.it www.sitrex.com

